



OIL & GAS DEVELOPMENT COMPANY LIMITED
PROCUREMENT DEPARTMENT (LOCAL), ISLAMABAD
SCHEDULE OF REQUIREMENT

Material : **OIL COOLERS FOR RECIPROCATING COMPRESSORS**

Due Date:

Tender Enquiry No: **LE-PT-P&P-18301**

Bid Bond Value : **RS.22,500/-**

EVALUATION WILL BE CARRIED OUT ON FULL

Attachment(if any) : **NIL**

Sr No	Description	Quantity	Make/Brand offered	Unit	Unit Price (PKR) Inclusive Of All Taxes Except GST	Unit Price (PKR) Inclusive of GST	Total Price (PKR) Inclusive of GST	Delivery Period Offered	deviation from Tender Spec. If Any
1	Oil Cooler Part no. 587-0067 Make: Thermal Transfer Products (API Heat Transfer Inc.) or equivalent, Complete unit as per attached drawing	1		Number					
2	Oil Cooler Part no. 587-0068 Make: Thermal Transfer Products (API Heat Transfer Inc.) or equivalent, Complete unit as per attached drawing	1		Number					

Special Note: The prospective bidders also download the master set of Tender Document

- The prospective bidders may keep in touch with OGDCL web site for downloading the clarifications/amendments (if any) issued by OGDCL.
- MATERIAL TO BE DELIVERED AT NASHPA FEILD, WITHIN 90 DAYS FROM THE DATE OF ISSUANCE OF LPO. PAYMENT WILL BE MADE AFTER DELIVERY. BID VALIDTY IS 90 DAYS AFTER TECHNICAL BID OPENING.

=====
TERMS AND CONDITIONS OF SUPPLY
=====

1. The oil coolers must be new and should be supplied in OEM packing.
2. The coolers to be supplied must be identical to the coolers w.r.t. shape, size / dimension, specifications, inlet outlet points, foundations / points of installation and functioning with part nos. as mentioned in the line items, manufactured by Thermal Transfer Products - a division of API Heat Transfer.
3. OEM documentation must be supplied in case any model is obsolete / alternate part no.
4. Delivery period is 03 months after issuance of L.P.O.

Handwritten signature

Handwritten mark



OIL & GAS DEVELOPMENT COMPANY LIMITED
PROCUREMENT DEPARTMENT (LOCAL), ISLAMABAD
SCHEDULE OF REQUIREMENT

Mandatory Checklist

Please confirm the compliance of the following mandatory information along with the bid(s) (failing which bids(s) will not be accepted)

Documents	To be Attached with the Technical/Financial Bids	Compliance	
		Yes <input type="checkbox"/>	No <input type="checkbox"/>
Original Bid Bond	Technical Bid	Yes <input type="checkbox"/>	No <input type="checkbox"/>
Copy of NTN Certificate	Technical Bid	Yes <input type="checkbox"/>	No <input type="checkbox"/>
Copy of GST Certificate	Technical Bid	Yes <input type="checkbox"/>	No <input type="checkbox"/>
Confirmation that the Firm is appearing on FBR's Active Taxpayer List	Technical Bid	Yes <input type="checkbox"/>	No <input type="checkbox"/>
Duly signed and stamped Annexure-A (Un-priced)	Technical Bid	Yes <input type="checkbox"/>	No <input type="checkbox"/>
Duly filled, signed and stamped Annexure-B	Technical Bid	Yes <input type="checkbox"/>	No <input type="checkbox"/>
Duly filled, signed and stamped Annexure-D	Technical Bid	Yes <input type="checkbox"/>	No <input type="checkbox"/>
Duly filled, signed and stamped Annexure-L on Company's Letterhead	Technical Bid	Yes <input type="checkbox"/>	No <input type="checkbox"/>
Duly signed and stamped Annexure-M on Company's Letterhead	Technical Bid	Yes <input type="checkbox"/>	No <input type="checkbox"/>
Duly signed and stamped Annexure-N on Non-Judicial Stamp Paper duly attested by Notary Public	Technical Bid	Yes <input type="checkbox"/>	No <input type="checkbox"/>
Duly filled, signed and stamped Annexure-A (Priced)	Financial Bid	Yes <input type="checkbox"/>	No <input type="checkbox"/>
Duly filled, signed and stamped Annexure-C	Financial Bid	Yes <input type="checkbox"/>	No <input type="checkbox"/>
Duly filled, signed and stamped Annexure-E	Financial Bid	Yes <input type="checkbox"/>	No <input type="checkbox"/>



OIL & GAS DEVELOPMENT COMPANY LIMITED
PROCUREMENT DEPARTMENT (LOCAL), ISLAMABAD
SCHEDULE OF REQUIREMENT

For the Vendors/Contractors who opt to submit Bank Draft/Call Deposit/Pay order against Bid Bond/Performance Bond, our Accounts Department has finalized an arrangement for online payment to such Vendors/Contractors, which will be processed through (IBFT & LFT) for which following information is required:

i.	IBAN No. (International Bank Account Number 24 Digits)	
ii.	Vendor Name as per Title of their Bank Account	
iii.	Contact No.of Company's CEO/ Owner (Mobile & Landline)	
iv.	Bank Name.	
v.	Bank Branch Name and Code	

Name, Sign and Stamp of the authorized official of the Bidder(s) _____

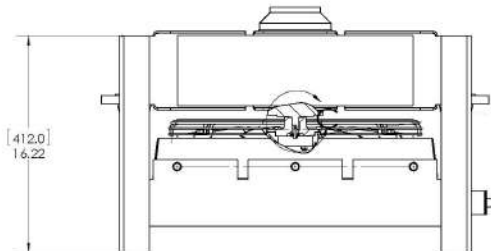
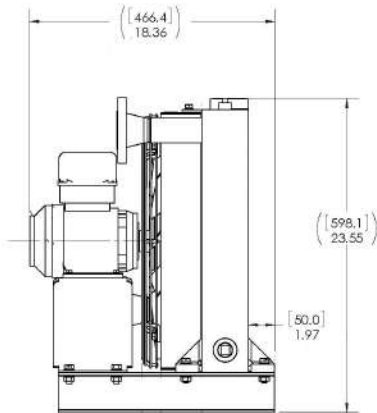
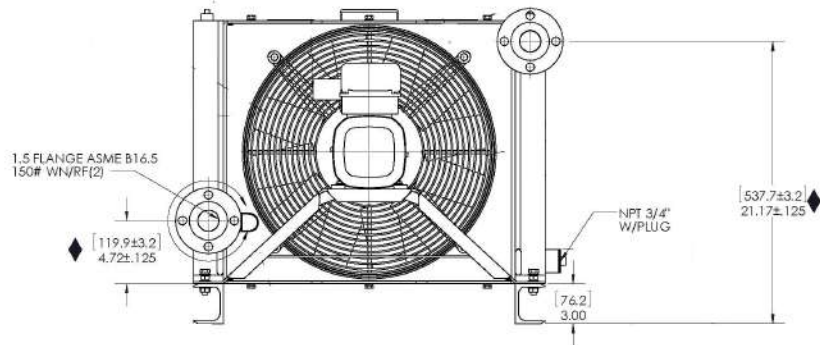
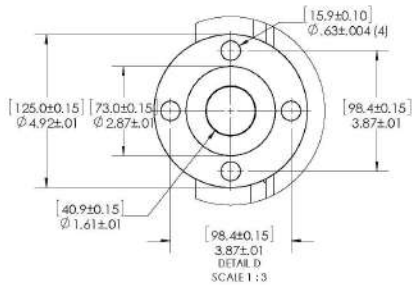
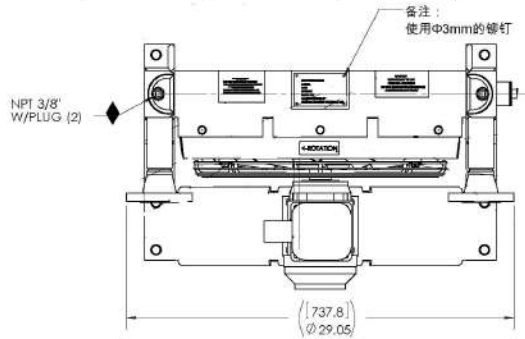

INTERNAL DESIGN PRESSURE
 DD: 250PSIG @ 300°F
 CUSTOMER P/N
 ALL DIMENSION IN INCHES (mm)
 DO NOT SCALE DRAWING

THIS DOCUMENT CONTAINS PROPRIETARY AND CONFIDENTIAL INFORMATION AND MAY NOT BE DISCLOSED TO OTHERS FOR ANY PURPOSE OR USED FOR MANUFACTURING PURPOSES WITHOUT WRITTEN PERMISSION FROM API HEAT TRANSFER.

REMARKS:



NO.	REVISION	BY	DATE	CHK'D BY	DATE
1	焊接底座改成螺栓连接	KW	160913		
2					
3					
4					
5					

OIL COOLER
 HT-3101

STANDARD TOLERANCE
 DD 2768-V
 F: NET DIMENSION
 SPECIFIED
 C: ±0.125
 M: ±0.125
 H: ±0.125
 K: ±0.125
 L: ±0.125
 P: ±0.125
 R: ±0.125
 S: ±0.125
 T: ±0.125
 U: ±0.125
 V: ±0.125
 W: ±0.125
 X: ±0.125
 Y: ±0.125
 Z: ±0.125

Thermal Transfer Products
 A DIVISION OF API HEAT TRANSFER INC.

SIZE	DRAWING NUMBER	REV.
C	587-0067	1

NPT 3/8"
W/PLUG
[3]

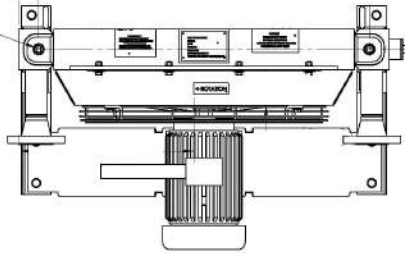

1.5" FLANGE ASME B16.5
150# WN/RF

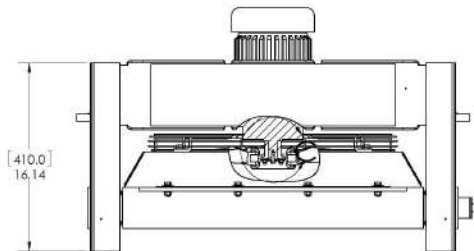
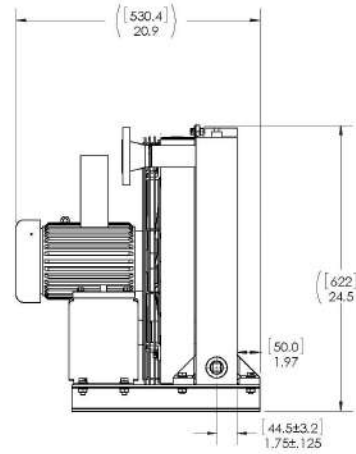
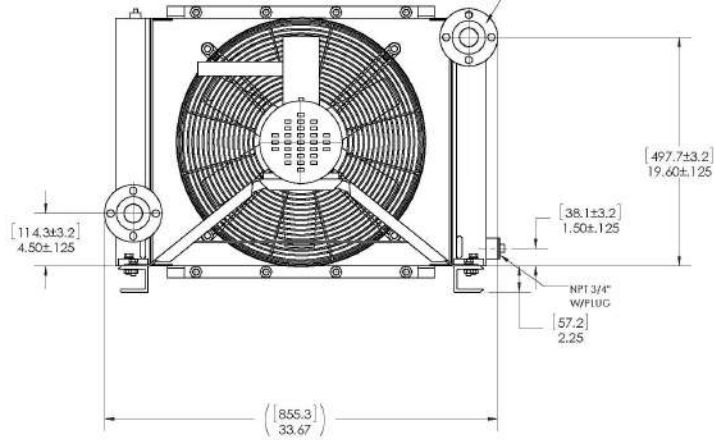

THIS DOCUMENT CONTAINS PROPRIETARY AND CONFIDENTIAL INFORMATION AND MAY NOT BE DISCLOSED TO OTHERS FOR ANY PURPOSE OR USED FOR MANUFACTURING PURPOSES WITHOUT WRITTEN PERMISSION FROM API HEAT TRANSFER.

REMARKS:



INTERNAL DESIGN PRESSURE

DC: 250PSIG @ 300°F

CUSTOMER P/N

ALL DIMENSION IN INCHES (mm)
DO NOT SCALE DRAWING

5					
4					
3					
2	螺絲M8*35改成M8*30	KW	161129		
1	焊接底座改成螺絲連接	KW	160918	CHK'D BY:	DATE:
NO.	REVISION	BY	DATE	BY	DATE

OIL COOLER
HT-3101A/B/C

STANDARD TO SPEC: DD 2768-V
IF NOT SPECIFIED SPECIFY:
C. + .01-.25
D. + .01-.25
E. + .01-.25
F. + .01-.25
G. + .01-.25
H. + .01-.25
I. + .01-.25
J. + .01-.25
K. + .01-.25
L. + .01-.25
M. + .01-.25
N. + .01-.25
O. + .01-.25
P. + .01-.25
Q. + .01-.25
R. + .01-.25
S. + .01-.25
T. + .01-.25
U. + .01-.25
V. + .01-.25
W. + .01-.25
X. + .01-.25
Y. + .01-.25
Z. + .01-.25

Thermal Transfer Products
A DIVISION OF API HEAT TRANSFER INC.

SIZE	DRAWING NUMBER	REV.
C	587-0068	2