



OIL & GAS DEVELOPMENT COMPANY LIMITED
PROCUREMENT DEPARTMENT (LOCAL), ISLAMABAD
SCHEDULE OF REQUIREMENT

Material : **PROCUREMENT OF GEAR BOX**

Due Date:

Tender Enquiry No: **PROC-LH/PT/P&P-18446**

Bid Bond Value : RS. 15000

EVALUATION WILL BE CARRIED OUT ON FULL

Attachment(if any) : YES

Sr No	Description	Quantity	Make/Brand offered	Unit	Unit Price (PKR) Inclusive Of All Taxes Except GST	Unit Price (PKR) Inclusive of GST	Total Price (PKR) Inclusive of GST	Delivery Period Offered	deviation from Tender Spec. If Any
1	GEAR BOX Part # T16-1:1-U-R-B3 Cooler Drive Gear box; Assembly: Kerui Compression Package (Ariel JGA/4 with Waukesha F18SE) ; Manufacturer: Boneng, China or equivalent – as per attached TOR and drawing	1		Number					

Special Note: The prospective bidders also download the master set of Tender Document

- The prospective bidders may keep in touch with OGDCL web site for downloading the clarifications/amendments (if any) issued by OGDCL.
- DELIVERY TERM: WITHIN 03 MONTHS AFTER ISSUANCE OF LPO ON F.O.R MELA OIL FIELD. PAYMENT TERM: 100% AFTER DELIVERY AND INSPECTION. BID VALIDITY: 120 DAYS FROM THE OPENING DATE OF TECHNICAL BID.



OIL & GAS DEVELOPMENT COMPANY LIMITED
PROCUREMENT DEPARTMENT (LOCAL), ISLAMABAD
SCHEDULE OF REQUIREMENT

Mandatory Checklist

Please confirm the compliance of the following mandatory information along with the bid(s) (failing which bids(s) will not be accepted)

Documents	To be Attached with the Technical/Financial Bids	Compliance	
		Yes <input type="checkbox"/>	No <input type="checkbox"/>
Original Bid Bond	Technical Bid	Yes <input type="checkbox"/>	No <input type="checkbox"/>
Copy of NTN Certificate	Technical Bid	Yes <input type="checkbox"/>	No <input type="checkbox"/>
Copy of GST Certificate	Technical Bid	Yes <input type="checkbox"/>	No <input type="checkbox"/>
Confirmation that the Firm is appearing on FBR's Active Taxpayer List	Technical Bid	Yes <input type="checkbox"/>	No <input type="checkbox"/>
Duly signed and stamped Annexure-A (Un-priced)	Technical Bid	Yes <input type="checkbox"/>	No <input type="checkbox"/>
Duly filled, signed and stamped Annexure-B	Technical Bid	Yes <input type="checkbox"/>	No <input type="checkbox"/>
Duly filled, signed and stamped Annexure-D	Technical Bid	Yes <input type="checkbox"/>	No <input type="checkbox"/>
Duly filled, signed and stamped Annexure-L on Company's Letterhead	Technical Bid	Yes <input type="checkbox"/>	No <input type="checkbox"/>
Duly signed and stamped Annexure-M on Company's Letterhead	Technical Bid	Yes <input type="checkbox"/>	No <input type="checkbox"/>
Duly signed and stamped Annexure-N on Non-Judicial Stamp Paper duly attested by Notary Public	Technical Bid	Yes <input type="checkbox"/>	No <input type="checkbox"/>
Duly filled, signed and stamped Annexure-A (Priced)	Financial Bid	Yes <input type="checkbox"/>	No <input type="checkbox"/>
Duly filled, signed and stamped Annexure-C	Financial Bid	Yes <input type="checkbox"/>	No <input type="checkbox"/>
Duly filled, signed and stamped Annexure-E	Financial Bid	Yes <input type="checkbox"/>	No <input type="checkbox"/>



OIL & GAS DEVELOPMENT COMPANY LIMITED
PROCUREMENT DEPARTMENT (LOCAL), ISLAMABAD
SCHEDULE OF REQUIREMENT

For the Vendors/Contractors who opt to submit Bank Draft/Call Deposit/Pay order against Bid Bond/Performance Bond, our Accounts Department has finalized an arrangement for online payment to such Vendors/Contractors, which will be processed through (IBFT & LFT) for which following information is required:

i.	IBAN No. (International Bank Account Number 24 Digits)	
ii.	Vendor Name as per Title of their Bank Account	
iii.	Contact No.of Company's CEO/ Owner (Mobile & Landline)	
iv.	Bank Name.	
v.	Bank Branch Name and Code	

Name, Sign and Stamp of the authorized official of the Bidder(s) _____

=====

TERMS AND CONDITIONS OF SUPPLY:

=====

1. The gear box must be new and should be supplied in OEM packing.
2. The gearbox must be compatible with the existing gear box with the part no. provided in the description of the item and attached drawing. (The part is installed on a compression package packaged by M/s Kerui, consisting of Ariel JGA/4 and Waukesha F18SE and is installed on the power train of the Gas / oil cooler of the package).
3. OEM documentation must be supplied in case the provided part no. is obsolete / alternate part no. exists.
4. Delivery period is 03 months after issuance of LPO.
5. Bidders quoting the gear box of equivalent brands / make should provide a certificate from at least 03 E&P / renowned companies of foreign jurisdiction other than bidders / manufacturers own country, stating that equivalent (quoted parts) are used by them and performance of such parts is found satisfactory. Copies of purchase Order (unpriced) must also be provided. The certificate(s) / sale record is mandatory and due to non-submission thereof, the bid will be rejected.

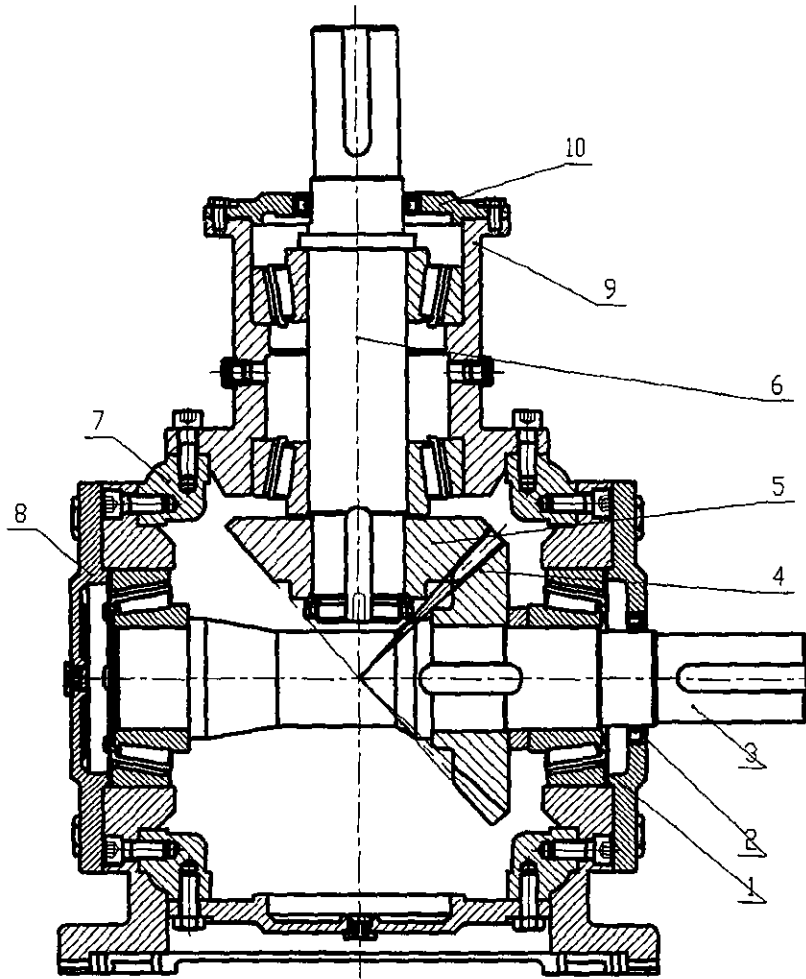

10	21322003000001-1	T12输入法兰端盖-01	T12 Input Flange Plate-01	1	HT200			
9	21127019500001-1	T16输入法兰座-01	T16 Input Flange Seat-01	1	HT200			
8	21327003000002-1	T16左右网盖-01	T16 End Plate-01)	4	HT200			
7	200T1600-00001-1	T16箱体-01	T16 Housing-01	1	HT200			
6	26008542000001-1	T16横轴i/1-01	T16 Single-extendable Shaft i/1-01	1	42CrMo			
5	22208002700004-1	T16主动锥齿轮i/1.000-01	T16 Action Bevel i/1.000-01	1	20CrMnTi			
4	22208002700003-1	T16从动锥齿轮i/1.000-01	T16 Driven Bevel i/1.000-01	1	20CrMnTi			
3	26008549000002-1	T16十字轴(齿侧)i/1-01	T16 Cross Pins i/1-01	1	42CrMo			
2	20700038A	油封 $\phi 65 \times \phi 90 \times 10$	lip seal $\phi 65 \times \phi 90 \times 10$	2	NBR			
1	20000144	圆锥滚子轴承32314	tapered roller bearing32314	4				
序号	产品编码	中文描述	English Description	数量	材 质	单重	总重	

					BONENG		T16-1:1-U-R-B3	
标记	数量	更改文件号	签字	日期				
设计		邵哲	日期	2020.02.12				
校对			日期					
审核		袁俊强	日期	2020.01.10	投影方式	版本	重量	比例
工艺			日期					
标准化			日期					
批准			日期					
					共 页 第 页		易损件清单	