

# **OIL & GAS DEVELOPMENT COMPANY LIMITED**



**TENDER ENQUIRY NO. PROC-SERVICES/CB/PE&FD-3056/2017**

**RATE RUNNING CONTRACT FOR ENGINEERING CONSULTANCY  
STUDIES, PROJECT MANAGEMENT AND INSPECTION  
SERVICES**



**OIL & GAS DEVELOPMENT COMPANY LIMITED**  
**SUPPLY CHAIN MANAGEMENT DEPARTMENT**  
**SERVICES SECTION**

OGDC HOUSE  
JINNAH AVENUE,  
ISLAMABAD – PAKISTAN

PHONE :+92-51- 92002 3780  
EMAIL: ejaz\_rizvi@ogdcl.com  
POST CODE : 44000

**SUBJECT: LETTER FOR INVITATION TO BID FOR RATE RUNNING CONTRACT  
FOR ENGINEERING CONSULTANCY STUDIES, PROJECT  
MANAGEMENT AND INSPECTION SERVICES AGAINST TENDER NO.  
PROC-SERVICES/CB/PE&FD-3056/2017**

**1. INTRODUCTION**

Oil and Gas Development Company Ltd (OGDCL) is Pakistan's leading E&P sector company, having operations at about 50 locations and fields in all the four provinces. The Company is listed and traded on all three stock exchanges of the country with highest market capitalization. Recently the Company, through GDR process, has also been listed on London Stock Exchange. More details about the Company can be obtained from its website [www.ogdcl.com](http://www.ogdcl.com).

**2. OBJECTIVE**

OGDCL Intends to hire subject Services as per Annexure-A. Interested bidders are required to submit their bids strictly as per Terms of Reference (TOR) / scope of work (Annexure-A) and instructions to bidders given in this tender document.

**3.** Sealed bids are hereby invited under Competitive Bidding (CB) procedure from eligible bidders from the countries maintaining bilateral trade relations with Pakistan for Services as listed in the Terms of Reference (TOR) "Annexure-A" of the attached Tender Documents. **The prices may be quoted as per details mentioned in TOR "Annexure-A".**

**4. PROSPECTIVE BIDDERS SHOULD PARTICULARLY NOTE THAT:**

4.1 Bids will be accepted only if the materials / services and supplies being offered are produced and manufactured in the country(s) maintaining bilateral relations with Pakistan. Bidder (s) participating in bidding process for provision of service (s) to OGDCL should invariably be registered with Provincial Revenue Authority at the time of submission of its bid to OGDCL.

4.2 Each bid valid for minimum 180 days from the date of opening of the bids must be accompanied by a Bid Bond in the form of a cash deposit receipt (CDR), a Bank Draft/Pay Order in favour of OGDCL or a Bank Guarantee issued by scheduled Bank of Pakistan or a branch of foreign bank operating in Pakistan, except NIB Bank, for an amount mentioned in clause#31 and valid for 210 days from the date of opening of bids. The Bank Guarantee will be issued by a scheduled Bank, except NIB Bank, in accordance with the format as per Annexure-B of the tender Documents.

4.3 Bid Bond through telex / fax shall not be acceptable.

4.4 On acceptance of the bid by the Purchaser the successful bidder shall be required to furnish Performance Bond / Bank Guarantee for an amount

equivalent to 10 % of the Contract value for the required Services in US Dollars or in currency of Bidder or equivalent in Pakistan Currency as per Annexure-C.

5. The Purchaser does not take any responsibility for collecting the bids from any Agency. Your authorized representative may attend the Tender opening if desired. The request for extension of closing date and time shall not be entertained and tender received after closing time or date shall be returned to Bidder unopened.
6. The Purchaser reserves the right to increase or decrease the quantities / Scope of Work and accept or reject any or all bids or cancel any or all items at anytime without assigning any reasons thereof.
7. The Purchaser reserves the right to have the items inspected by its own representatives or through third party, wherever applicable.
8. It must be indicated in the offer that the quotation fully conforms to Technical Specifications and Terms & Conditions of the Tender Enquiry.

**9. TIME AND PLACE FOR SUBMISSION FO BIDS.**

Bids must be delivered / dropped in the tender box / OGDCL reception at time & date mentioned in Press Tender Notice” at the following address:-

**Manager (SCM) Services**

Oil & Gas Development Company Limited  
Supply Chain Management Department  
OGDCL House, Jinnah Avenue, Islamabad (Pakistan)  
Phone No. 92-51-920023780/ 3652  
Email: ejaz\_rizvi@ogdcl.com

**10. OPENING OF BIDS**

Bids will be opened at the time and date mentioned in Press Tender Notice on the place noted above.

11. Any company registered at places e.g. Vigin, Cayman, Nausa, Jersey and Bohaman Islands shall not be entertained and bids if submitted shall be rejected.

**12. TWO ENVELOPE BIDDINGS**

1. Bids against this tender are invited on **Single Stage Two Envelope Bidding Procedure**; therefore, the bidders shall submit original and copy of their Technical and one original Financial bid.
  2. Tender Annexure to be added in both the bids; UN-Priced with technical Bids & Priced with Commercial Bids.
  3. Both the bids shall be submitted simultaneously in separate sealed inner and outer envelopes. The envelope containing Technical Bid must be marked clearly **“Technical Bid”** and containing Financial Bid must be marked clearly **“Financial Bid”** along with indication on the envelopes as **“ORIGINAL”** and **“COPY”**.
13. The Technical Bid will be opened at first and evaluated. The Financial Bid of only those bidders will be opened who are declared technically Responsive.

14. The Financial Bid must be complete in all aspects and comparable. Conditional Prices and/or Prices mentioned other than Rate Format/Financial Evaluation Criteria, may not be accepted. In case, the Bidder is not charging any rate and/or the rates are not applicable, Zero (0) must be clearly mentioned, failing which, the bid(s) may be considered as non-responsive.
15. The contract / service order will remain valid till completion of job / period specified in Terms of Reference (TOR) at Annexure "A". Any extension in validity of contract / service order will be subject to written mutual consent of both the parties.
16. The interested bidders must confirm their willingness to submit bid proposals at least ten (10) working days before the last date for bid submission, giving complete mailing address, email etc.
17. No alternation in OGDCL's uploaded tender documents is allowed. Any attempt for alteration/amendment in the tender documents may lead to disqualification of the bidder.
18. The Bank Guarantee, in any form, issued by NIB Bank shall not be accepted.

**MANAGER (SCM) SERVICES**  
**OIL & GAS DEVELOPMENT COMPANY LIMITED**  
**PHONE: 0092-51-92002 3780**  
**Email: ejaz\_rizvi@ogdcl.com**

## **INSTRUCTIONS TO BIDDER**

### **1. PROSPECTIVE BIDDERS SHOULD PARTICULARLY NOTE THAT:**

- 1.1 Bids valid for minimum of 180 days from the date of opening of bids, must be accompanied by Bid Bond (to be attached with **Technical Proposal**) in the form of a Bank Guarantee for an amount of USD/Pak Rupees(*mentioned at Clause-31*) and valid for 210 days from the date of opening of bids. The Bank Guarantee should be issued by a Pakistani Scheduled Bank or branch of a foreign bank operating in Pakistan, except NIB Bank, in accordance with the Format at **Annexure-“B”**.
- 1.2 Bid Bonds through fax shall not be acceptable.
- 1.3 On acceptance of Bid by the purchaser, the successful Bidder shall, within 15 days of the receipt of Letter of Intent (LOI) furnish an acceptable performance Bond/Bank Guarantee for an amount equivalent to 10% of the total contract value in US\$ or equivalent in Pak Rupees, issued by Pakistani Scheduled Bank or Branch of a Foreign Bank operating in Pakistan, except NIB Bank, in accordance with the Format at Annexure-C.
- 1.4 The Terms and Conditions form an integral part of Tender Enquiry and must be taken into consideration before submitting your quotation.
- 1.5 The Purchaser does not take any responsibility for collecting the Bids from any Agency. Your authorized representative may attend the Tender Opening if desired. The requests for extension of closing date and time shall not be entertained and tender received after closing time or date, shall not be accepted and returned to Bidders unopened.
- 1.6 The purchaser reserves the right to increase or decrease the quantities /scope of work to a reasonable percentage and accept or reject any or all bids or may cancel any or all items at any time without justifying any reasons therefore.

### **2. THE BIDDING DOCUMENTS COMPRISE OF THE FOLLOWING:-**

- a) Instructions to Bidders
- b) Terms of Reference / Scope of Work, (Annexure-**A**)
- c) Format of Bid Bond (Annexure-**B**).
- d) Format of Performance Bond/ Bank Guarantee (Annexure-**C**)
- e) Format of Bidding Form(Annexure-**D**)
- f) Format of Integrity and Ethics undertaking (Annexure-**E**)
- g) Affidavit for Not Black Listing (Annexure-**F**)
- h) Date Summary Sheet to be attached with technical bid (Annexure-**G**)
- i) Date Summary Sheet to be attached with financial bid (Annexure-**H**)
- j) Draft Contract /Draft Service Order (Annexure-**I**)

### **3. TIME AND PLACE FOR SUBMISSION OF BIDS**

Sealed Bids as per clause-18 of Instructions to bidders given in this document must be delivered / dropped in the office detailed as per time and date given in Press Tender Notice.

### **4. OPENING OF BIDS**

Bids will be opened at OGDCL House, Islamabad, as per time and date given in Press Tender Notice.

## 5. **PREPARATION OF PROPOSAL**

Contractors will prepare their bids in two parts i.e. Technical Proposal (Part-I) and Financial Proposal (Part-II). Technical bid shall consist of one original and one copy whereas financial bid shall consist of original only and both the bids should be sealed in separate envelopes.

**TECHNICAL PROPOSAL:** should demonstrate firm's capability to provide the required Services and its understanding of the requisite tasks set forth in the Tender Document. Availability of the following information / documents in the technical proposal must be ensured for proper evaluation of the bid.

(i). Requested information/ sheets, in full with reference to the instructions given in **Terms of Reference/ Scope of Work** at Annexure-"A".

(ii). Background, organization and experience of bidding firm and of any firm that would be associating with for the purpose of providing the services for this project/contract. A list of past and present major work(s) of similar nature / type i.e carried out, or being carried out, by bidding and associate firm, if any with evidence in shape of work completion certificate or duly signed contract.

(iii). General approach or methodology proposed for carrying out job including all detailed information, as may be deemed relevant.

(iv). Unpriced draft agreement.

(v). Unpriced copy of financial bid.

If the bid is submitted by a joint venture of two or more companies, then the portion(s) of the project work to be carried out by each joint venture partner shall be very clearly identified.

Name, qualification, employment record and detailed professional experience of each expert, to be assigned for providing the proposed services, with particular reference regarding similar assignments undertaken by the bidder should also be provided in the bid. In proposing the personnel for this work, it will be encouraged to associate with domestic contractor(s) who are qualified to provide part of the services required.

Association agreement shall have to be produced by the joint venture partners accepting responsibility for the successful completion of the project separately and jointly.

**FINANCIAL PROPOSAL:** Financial Proposal should contain:

- (i) This tender document duly signed and stamped by the bidder.
- (ii) Duly filled in "Format For Rates" in accordance with instructions given in **Terms of Reference /Scope of work (TOR)** at (Annexure-"A").

All pages of the bid proposal shall be signed and stamped by duly authorized representatives of the bidder. Proof of authorization shall be furnished in the form of valid written power of attorney, which shall accompany the bid. The person signing the bid shall initial all pages of the bid where entries are made.

### **BID PRICE:**

- a. Bid price shall be inclusive of all taxes (except Provincial Sales Tax/ ICT Tax on services), duties, levies, charges etc.

- b. The prices should be quoted in USD. However payment to all Pakistan based companies will be made through cross cheque in 100% Pak Rupees, at actual, against verified invoices at official exchange rate prevalent on the date of payment.
- c. To Foreign based Companies, the payment will be made in US\$ at actual against verified invoices through Irrevocable Letter of Credit(LC)
- d. The prices charged by the successful bidder (contractor) for required services shall not vary from the prices quoted by the service company.

**6. COST OF BIDDING.**

The bidder shall bear all costs associated with the preparation and submission of his bid and OGDCL will in no case be responsible or liable for those costs, regardless of the outcome of the bidding process.

**7. ADDITIONAL SERVICES**

Contract price will be subject to adjustment as a result of addition/reduction in scope of work. However, unit price quoted for such work shall be used as base price for computation of final invoice. Contractor should take approval for such changes in writing from OGDCL. Rates and quantum of any additional job, not covered in the scope of work shall be subject to approval of OGDCL.

**8. UNSKILLED LABOUR**

Unskilled labor for handling tools and equipments will be on account of bidder.

**9. LANGUAGE OF BIDDING**

The bid must be prepared and submitted in the English language. Supporting documents and printed literature furnished by the bidder with the bid may be in another language as long as they are accompanied by an English translation of the pertinent passages. For the purpose of interpretation of the Bid, the English language shall prevail.

**10. BID VALIDITY.**

- 10.1. The Bid shall remain valid and open for acceptance for a period of 180 days from the specified date of tender opening.
- 10.2. In exceptional circumstances prior to expiry of the original bid validity period, the bidder may be requested in writing for an extension of the period of validity. A bidder agreeing to such request will not be permitted to modify his bid.

**11. ALTERNATIVE BIDS.**

- 11.1 In the event that the bidders submit an Alternative bid(s) whether in whole or against any of the items, a group of sub group, in addition to its Main Bid, the bids must be marked as “**Main Bid**” and “**Alternative Bid**”. Alternative Bids which don't conform to the specifications may be submitted. However, only the Alternative bid of the Bidder whose Main Bid is the lowest evaluated bid will be considered.
- 11.2 A Bidder, who wishes to have its Alternative bid(s) considered on an equal basis with all other (Main) bids, must submit a **Bid Bond** for each Alternative bid. An Alternative bid must be submitted in a sealed envelope clearly marked “**Alternative Bid**”, separate from the Main bid.

## **12. BID BOND.**

- 12.1 The bidder shall furnish with the **Technical bid proposal**, as part of his bid, a bid bond for an amount of US\$ /Pak Rupees (*mentioned at Clause-31*).
- 12.2 The Bid Bond in the form of a cash deposit receipt (CDR), a Bank Draft, CDR or a Bank Guarantee issued by scheduled Bank of Pakistan or a branch of foreign bank operating in Pakistan, except NIB Bank, for an amount mentioned in Clause#31 and valid for 210 days from the date of opening of bids. The Bank Guarantee will be issued by a scheduled Bank in accordance with the format as per Annexure-B of the tender Documents.
- 12.3 Any bid not accompanied by the requisite Bid Bond is likely to be declared non-responsive. The bid bond of unsuccessful bidders will be returned. The bid bond of the successful bidder shall be discharged after he has executed the contract.
- 12.4 The bid bond may be forfeited if a bidder withdraws his bid during the period of bid validity or if the Bidder, having been notified of the acceptance of his bid by the Company during the period of bid validity:
- 12.4.1 Fails, refuses or delays to execute the Contract in accordance with the instruction to Bidders, or
- 12.4.2 Fails, refuses or delays to furnish Performance Bond in accordance with the instruction to Bidders.

### **Note:**

“As regards to the requirement of Bid Bond, PPRA rule does not distinguish between any private or public entity, therefore, bidders are required to submit bid bond irrespective of their status as private bidder or public sector bidder”.

Non submission of bid bond of required value by the bidders shall summarily result in disqualification of their bid.

## **13. AMENDMENT OF BIDDING DOCUMENTS.**

- 13.1 At any time prior to the deadline for submission of Bids, OGDCL may, for any reason, whether at its own initiative or in response to a clarification requested by a prospective Bidder, modify the Bidding Documents by amendment.

**13.2** The amendment shall be part of the Bidding Documents, and will be notified to all the prospective bidders by uploading the same on OGDCL website.

## **14. CLARIFICATION(s) / QUERIES OF TENDER**

The bidders are expected to carefully examine all instructions, forms and specifications in the Bidding Documents. Any bidder in doubt as to the exact meaning or interpretation of any part of the Bidding Documents should immediately seek clarification in writing from;

**Manager (SCM) Services  
Oil and Gas Development Company Ltd,  
Jinnah Avenue, Islamabad, Pakistan  
Phone #. 0092-51-920023780/ 3652  
Email: ejaz\_rizvi@ogdcl.com**



For requests of all clarifications in regard to the information contained in Tender Documents made over the telephone shall not be entertained. All inquiries about the tender made to OGDCL and OGDCL's response will be made known to other bidders without disclosing identity of the bidder who made the enquiry.

**15. CONTRADICTIONS, OBSCURITIES AND OMISSIONS**

The Bidder should likewise notify the above of any contradictions, obscurities and omissions in the Bidding Documents if clarification of these is necessary for the clear understanding of the documents and for preparation of the bid. Such enquiries, clarifications, queries with reference to clause - 14 above must reach the above named not later than two weeks before the bid submission date otherwise the same will not be responded by OGDCL.

**16. DEADLINE FOR SUBMISSION OF BIDS.**

- 16.1 The original bid, together with the required copies must be delivered to OGDCL at the address specified in clause-18, not later than the time and date specified *in Press Tender Notice*.
- 16.2 OGDCL may, at its discretion, extend the deadline for the submission of Bids by amending the Bidding Documents in accordance with Clause-13, in which case all rights and obligations of OGDCL and bidders previously subject to the deadline will thereafter be subject to the deadline as extended.
- 16.3 Bids will be opened in presence of the bidder's representative who chooses to attend the bid opening at the time and date mentioned in the Tender Notice or on the extended date with reference to clause - 16.2.
- 16.4 The envelopes shall indicate the name and address of the bidder to enable the bid to be returned unopened in case it is declared "LATE".
- 16.5 If the envelopes are not marked as instructed below, OGDCL will assume no responsibility for the misplacement or premature opening of the bid.
- 16.6 In case due date bids opening falls on holidays, the bid will be opened on next working day.

**17. MODIFICATIONS AND WITHDRAWAL OF BIDS.**

- 17.1 Bidder may modify or withdraw his bid after submission, provided that written notice of the modification or withdrawal is received by OGDCL prior to the prescribed deadline for submission of bids.
- 17.2 The Bidder's modification or withdrawal notice shall be prepared, sealed, marked and dispatched as for the bid.
- 17.3 No bid shall be modified subsequent to the deadline for submission of bids and before the expiry of the period of bid validity.
- 17.4 No bid shall be withdrawn in the interval between the deadline for submission of bids and the expiry of the period of bid validity.

**18. SEALING, MARKING AND TRANSMISSION OF THE BID**

- 18.1 Your detailed "**Technical Proposal**" and "**Financial Proposal**" should be submitted in separate envelopes. The envelopes containing Technical and Financial Proposals shall be properly sealed, stamped and marked as follows:

**(a) Bid against TENDER ENQUIRY NO. ((As per Press Advertisement)).  
Do not open before ((As per Press Advertisement)) Hours (PST) of Bid  
opening date ((As per Press Advertisement)).**

**TECHNICAL PROPOSAL**

(As per Press Tender Notice)

**Manager (SCM) Services**

**OGDCL House, Jinnah Avenue, Islamabad.**

**Ph: # 051-920023780/ 3652, email: ejaz\_rizvi@ogdcl.com**

**(b) Bid against TENDER ENQUIRY NO.** (As per Press Tender Notice)

**Do not open before** (As per Press Tender Notice)  
Hours (PST) of Bid opening date: (As per Press Tender Notice)

**FINANCIAL PROPOSAL**  
**(As per Press Advertisement)**

**Manager (SCM) Services**  
**OGDCL House, Jinnah Avenue, Islamabad.**  
**Ph: # 051-920023780 / 3652, email: ejaz\_rizvi@ogdcl.com**

- 18.2 If the envelope is not marked as instructed above, OGDCL will assume no responsibility for the misplacement or premature opening of the bid.
- 18.3 In addition you should advise by fax to OGDCL of the dispatch of your proposal.

**19. LATE BIDS**

Any Bid received after deadline for submission of Bids prescribed by OGDCL pursuant to Clause- 16 above will be rejected and returned unopened to the bidder.

**20. BID OPENING**

The Bid shall be opened publicly in the Procurement Department of OGDCL by the Tender Opening Committee in the presence of Bidder's representatives who choose to attend the bid opening at the time and date specified in Press Tender Notice or on the extended date with reference to clause- 16.2 above.

**21. EVALUATION OF PROPOSALS.**

Technical proposal of the bid shall be reviewed first to determine / check its technical responsiveness and conformity with the requirement of bid. The technical evaluation shall be carried out on the basis of information /data spelled out at Annexure "A"/ITB provided with this document. Technically responsive and financially lowest evaluated bidder in line with the bid evaluation criteria given in the scope of work /TOR will be considered for award of job.

**22. CRITERIA FOR SUMMARY REJECTION.**

Bidder should ensure to submit their bids meeting following summary criteria failing which their bids are likely to be considered non responsive for detailed evaluation.

- 22.1 The Bid must be prepared in the English Language.
- 22.2 The Bid must be unconditionally valid for 180 days from the date of Bid Opening.
- 22.3 The Technical bid must be accompanied with the duly signed and stamped "Bidding Form" given at Annexure "D" of the tender documents without any exception/ deviation.
- 22.4 Bids should not be submitted in the form of Telex or Telegram.
- 22.5 Bid must reach before as mentioned in the Tender Notice or as per clause-16.
- 22.6 Technical Bid must be accompanied by a bid bond as specified in Clause - 12.
- 22.7 Direct fax bid shall not be acceptable. However, fax bid in sealed envelope confirming all other formalities as stated above will be acceptable provided original bid is received by OGDCL within 07 days of the Bid Opening Date failing which such bid will be considered non-responsive.

- 22.8 The bid proposal should essentially include C.Vs of the professionals expected to be deployed for the job (if required).
- 22.9 The Purchaser will evaluate and compare only the substantially responsive bids.
- 22.10 Bids determined to be substantially responsive will next be checked for any material error in computation.
- 22.11 Technical bid must be accompanied by Affidavit (Annexure-F) for Not Black Listing. The procedure of Black Listing is available at OGDCL website at following link:  
<http://ogdcl.com/uploads/tender/BlackListingProcedure.pdf>

**23. CLARIFICATION OF BIDS.**

To assist in the examination, evaluation and comparison of Bids OGDCL may at its discretion, ask the Bidder for clarification of his Bid. All responses to request for clarification shall be in writing, and no change in the price or substance of the Bid shall be sought, offered or permitted.

**24. ELIGIBILITY AND QUALIFICATION REQUIREMENTS**

- 24.1 To be eligible for award of contract, bidders shall have to provide satisfactory evidence to OGDCL of their eligibility, capability and adequacy to carry out the contract effectively up to the end. All bids submitted shall include updates of the information on technical capability and firm's history that includes experience, list of similar projects carried out as per requirement of the Scope of work / TOR.
- 24.2 Proof of requirements mentioned at Sub-clause-24.1 must be submitted by the bidder along with the bid.
- 24.3 Bids submitted by a joint venture of two or more firms as partners shall comply with the following requirements:
  - 24.3.1 The bids, and in case of a successful bid, a Form of Agreement shall be signed so as to be legal binding on all partners.
  - 24.3.2 One of the partners shall be nominated, as being in charge and it's authorization shall be evidenced by submitting a power of attorney signed by legally authorized signatories of all the partners.
  - 24.3.3 The partner in charge shall be authorized to incur liabilities and receive instructions for and on behalf of any and all partners of the joint venture and the entire execution of the contract including payment shall be done exclusively with the partner in charge.
  - 24.3.4 All partners of the joint venture shall be jointly and severally responsible for the execution and completion of the contract in accordance with the contract terms and conditions. A relevant statement to this shall be included in the authorization mentioned under clause-24.3.2 as well as in form of bid and the form of Agreement (in case of successful bid). A copy of the agreement entered into the joint venture partners shall be submitted with the bid.

**25. COMPANY'S RIGHT TO ACCEPT OR REJECT ANY OR ALL BIDS.**

OGDCL reserves the right to accept or reject any bid and to annul the bidding process and reject all bids at any time prior to award of contract, without thereby incurring any liability to the effected bidder or bidders or any obligation to justify the affected bidder or bidders of the grounds for OGDCL's action.

**26. GENERAL TERMS AND CONDITIONS.**

- 26.1 After opening the bids, OGDCL will determine whether each bid is substantially responsive to the requirements of the Bidding Documents.

- 26.2 OGDCL will examine the bids to determine whether they are complete, whether any computational errors have been made, whether required experience certificates/ evidence, sureties have been furnished, whether the documents have been properly signed, and whether the bids are generally in order.
- 26.3 Arithmetical errors will be rectified on the following basis. If there is a discrepancy between the unit price and the total price that is obtained by multiplying the unit price and quantity, the unit price shall prevail and the total price shall be corrected. If there is a discrepancy between words and figure, the amount in words shall prevail.
- 26.4 A substantially responsive bid is one, which conforms to all the terms and conditions of the Bidding Documents without material deviation. A material deviation is one which being inconsistent with the Bidding Documents, affects in any substantial way the scope, instruction to Bidders, quality or prescribed completion schedule or which limits in any substantial way, OGDCL's right or the bidders' obligation under the Contract.
- 26.5 A bid determined to be non-responsive will be rejected by OGDCL and shall not subsequently be made responsive by the Bidder by correction of the non-conformity.
- 26.6 OGDCL may waive any minor deviation non-conformity or irregularity in a bid, which does not constitute a material deviation, provided that the waiver does not prejudice or affect the relative standing order of any Bidder.
- 26.7 To assist in determining a bid's responsiveness the Bidder may be asked for clarification of his bid. The Bidder is not permitted, however, to change bid price or substance of his bid.
- 26.8 The evaluation of the bids will take into account, in addition to the bid price, the following factors:
- a) Reliability and efficiency of the offered Service.
  - b) Financial standing of the supplier.
- 26.9 The award of the Contract/Service Order shall be made to the Bidder whose bid has been determined to be the lowest evaluated bid, after considering all factors and who meets the requisites of Schedule of Requirement (Scope of Work/Bid Format).
- 26.10 The purchaser shall notify by fax/letter, the successful bidder of its intent to enter into a contract. The contract shall be executed only after all necessary management/Governmental approvals have been obtained.
- 26.11 The bidders may lodge a written compliant for redressal of their grievances and disputes to Committee for Redressal of Grievances & Settlement Dispute within fifteen (15) days of the placement of the Technical Evaluation Report on the web.

**27. PERFORMANCE BOND / BANK GUARANTEE**

- 27.1 Within fifteen (15) days of receipt of the notification of contract award, the successful bidder shall furnish to OGDCL, the Bank Guarantee / Performance Bond for an amount equivalent to 10% of contract value as per specimen at "Annexure-**C**".
- 27.2 The bank guarantee / performance bond shall remain valid and in full force and effect during validity of the contract.
- 27.3 The validity of Bank Guarantee / Performance Bond shall be extended by the contractor if the completion of contract is delayed, whether in whole or in part.

- 27.4 The cost incurred for establishing the Bank Guarantee / Performance Bond or any extension thereof shall be to the account of the contractor.
- 27.5 The Bank Guarantee / Performance Bond will be discharged after completion of the contract.
- 27.6 The Bank Guarantee must be as per format attached at Annexure-”C” and must be either from a Pakistan scheduled bank or from a branch of foreign bank operating in Pakistan, except NIB Bank, acceptable to OGDCL.
- 27.7 The proceeds of the Performance Bond shall be payable to the company (OGDCL) as compensation for any loss resulting from the contractor’s failure to complete its performance obligations under the contract.
- 28. EMPLOYMENT OF PAKISTANI NATIONALS:**
- 28.1 The Contractor will be required to employ Pakistani Qualified & experienced nationals in its operation if available. In order to employ the expatriate professionals if needed, the contractor will ensure that all out efforts have been exhausted to employ Pakistani qualified nationals. Unskilled workers if needed for the operation will be hired from the area where the operation is being performed.
- 28.2 In case of non availability of qualified / experienced Pakistani nationals for the contractual services, the contractor will reasonably make efforts to train Pakistani nationals in such a manner to replace gradually the expatriate professionals.
- 29. SIGNING OF CONTRACT**
- Within 15 days after notification to the successful bidder regarding acceptance of his bid, the contract incorporating all agreements between the parties will be signed.
- 30. SOURCE OF FUNDS.**
- The Project will be financed out of funds of the Company (OGDCL).
- 31. AMOUNT OF BID BOND**
- Amount of bid bond referred to in Clause-12 of Instruction to Bidders, and Annexure-“B” of this tender enquiry shall be
- **PKR 2,600,000/- PAK RUPEES TWO MILLION SIX HUNDRED THOUSAND ONLY.**
- 32. DEADLINE/ TIME AND PLACE FOR SUBMISSION OF BIDS (REFER CLAUSE-34 OF INSTRUCTIONS TO BIDDERS):**
- Sealed bids in duplicate as per Clause-18 of Instructions to bidders of this tender enquiry must be delivered / dropped in the office detailed therein until **(As per Press Tender Notice)** Pakistan Standard Times (“PST”) on **(As per Press Tender Notice)**.
- 33. OPENING OF BIDS (REFER CLAUSE-34 OF INSTRUCTIONS TO BIDDERS).**
- Bids will be opened at *(As per Press Advertisement)* (“PST”) on **(As per Press Tender Notice)** at OGDCL House, Islamabad, Pakistan.
- 34. SEALING, MARKING AND TRANSMISSION OF THE BID (REFER CLAUSE -18 OF INSTRUCTIONS TO BIDDERS).**
- 34.1. Your detailed “Technical Proposal” and “Financial Proposal” should be submitted in one original and one copy of each in separate envelopes.

The envelopes containing Technical and Financial Proposals shall be properly sealed, stamped and marked as follows:-

- (a) Bid against TENDER ENQUIRY NO. (As per Press Tender Notice)  
Do not open before (As per Press Tender Notice) (PST) of Bid opening date: (As per Press Tender Notice)

**TECHNICAL PROPOSAL**  
**(As per Press Tender Notice)**  
**Manager (SCM) Services**  
**OGDCL House, Jinnah Avenue, Islamabad.**  
**Ph: 051-92002 3780, / 3652, email: ejaz\_rizvi@ogdcl.com**

- (b) Bid against TENDER ENQUIRY (As per Press Tender Notice)  
Do not open before (As per Press Tender Notice) (PST) of Bid opening date:  
(As per Press Tender Notice).

**FINANCIAL PROPOSAL**  
**(As per Press Tender Notice)**  
**Manager (SCM) Services**  
**OGDCL House, Jinnah Avenue, Islamabad.**  
**Ph: 051-92002 3780, / 3652, email: ejaz\_rizvi@ogdcl.com**

- 34.2 If the envelope is not marked as instructed above, OGDCL will assume no responsibility for the misplacement or premature opening of the bid.
- 34.3 In addition you should advise by fax to OGDCL of the dispatch of your proposal.
35. Material Deficiencies which will lead to disqualification
- (i) Failing to get minimum qualifying marks in the technical evaluation
  - (ii) Reflect or demand of deviation from TOR of this Tender Enquiry will lead to disqualification.

# **TERMS OF REFERENCE (TOR)**

## **RATE RUNNING CONTRACT FOR ENGINEERING CONSULTANCY STUDIES, PROJECT MANAGEMENT AND INSPECTION SERVICES**

### **RATE RUNNING CONTRACT FOR ENGINEERING CONSULTANCY STUDIES, PROJECT MANAGEMENT AND INSPECTION SERVICES**

The intent of this document is to carry out the oil & gas field engineering studies through rate running engineering consultancy jobs for three years period and the contract can be extended further by one year, if mutually agreed. Bids are invited under Single Stage Two Envelop Bidding Process of PPRA. No price adders are allowed.

1. Introduction.

i. Oil & Gas Development Company Limited (OGDCL; mentioned as the Company or Client hereafter), the largest national Oil & Gas Exploring & Production Company in Pakistan intends to execute a three years based (extendable by one more year, with mutual agreement) “RATE RUNNING CONTRACT FOR ENGINEERING CONSULTANCY STUDIES, PROJECT MANAGEMENT AND INSPECTION SERVICES” with a Pakistan based, experienced and qualified engineering consultancy company (companies / or in case of lowest Group wise rates: a number of companies) having a major field of work in upstream oil & gas, exploration & production; pipeline and facilities tie-in portfolio for detailed design engineering consultancy and inspection, project support services as per scope and deliverables on group wise evaluation basis. There could be two, three or more companies for the part/group wise contract award under this tender/contract. The typical assets listed in the following scope of work are to be covered.

- a. Well Head Assemblies (WHAs),
- b. Oil / Gas Pipeline & Gathering Facilities
- c. Oil / Gas Processing Plant Facilities, Assets, equipment's etc.

ii. OGDCL's wells sites, pipeline infrastructure, tie-in points, separations facilities, compressors, fields assets or as in independent operations set ups are spread across the country in all region (as per details given below). These engineering services and consultancy jobs are to be conducted at following fields / locations (or nearby or accessible) on “As & When Required Basis” against a rate-running contract for a period of three years expendable for further one year with mutual agreement.

iii. Regional-wise names of well locations / pipeline networks / tie-in / fields / plants are given below;

A. Sindh Region:

- a. Bobi oil complex including all its satellite fields Chakdim. Mithrao, Dhamraki, LalaJamali, Suleman, Arradinetc&Bobi Processing plant.
- b. Sinjhoru Field and processing plant.
- c. TandoAlam oil complex including all its satellite field locations such as Pasakhi, Thora, Lashari, Sono, Daru etc.
- d. Kunnar field and processing plant including KPD-TAY wells and processing plant.
- e. QadirPur gas field and processing plant.

- f. Hundi/Sari gas field and dehydration plant.
  - g. Maru-Reti Field.
  - h. Sara West Field
  - i. Tando Allah yar.
  - j. Noor-Bagla Field.
  - k. Jakhro Field
  - l. Any other Field etc. in the region.
- B. Balochistan Region:
- a. Uch gas field including sale gas line, delivery station & processing plant
  - b. Uch – II gas field & processing plant
  - c. Loti Gas Field and Processing plant.
  - d. PirKoh Gas Field and Processing plant.
  - e. JhalMagsi gas field.
  - f. Any other field in the region.
- C. Punjab Region:
- a. Dhodak Gas-Condensate Field and Processing plant.
  - b. NandPur / PanjPir/ BahuFields and processing plant.
  - c. Dakhni Gas-condensate field and processing plant.
  - d. Sadqal Oil Field.
  - e. Fimkassar /Kal / ChakNaurang Oil Field.
  - f. Rajian Oil Field.
  - g. Any other field in the region.
- D. Khyber-Pakhtoonkhwa Region:
- a. Chanda Oil Field and Processing plant.
  - b. Mela Oil Field and Processing Plant.
  - c. Nashpa Oil Field.
  - d. Any Other Field in the region.

NOTE: New exploratory wells locations for review may not be covered in the above list, but these new facilities would be covered as an essential part of this contract. Same would be covered under nearby OGDCL locations for administrative and logistical support.

2. List of Assets.

The assets general descriptions are to cover minimum following listed assets but not limited to;

i. Well Head Assemblies (WHA's) and Production Facilities:

These assets at the downstream of Christmas tree CHOKE include all pipelines, pipe fittings such as elbows, tees, reducers / expanders, test separators / line heaters (heater), cyclone separators, knock-out vessels etc. These assets start from Choke of X-Mass tree to weld joint of under-ground flow line / spur line. There are variety of different phase flow ( oil,gas, Water and mix phase) on each individual field and having different diameter ( 2” ,4” ,6” ,8” ,10” ,12” ,etc) & different length (exposed or buried; coated/ insulated or bare flow lines) of well head assemblies (30-75 Meters approx.) with different material specification. Detailed data for each field will be provided at the time of job order. Includes WH control panel and optional SCADA systems for monitoring & controls.



ii. Oil / Gas Pipeline & Gathering Facilities:

These assets include but not limited to pig launching & receiving units, exposed pieces of main gas gathering header(s) & flow lines having different, length, material, schedule and diameter (4", 8", 10", 12", 14", 16", 20", 24", 26", 30", etc.). These lines are used for all type of phase flow at different temperatures and pressures with or without SCADA system for monitoring & controls. Detailed data for each field will be provided at the time of job order.

From financial point of view following will be treated as given in financial bid format;

- a. Pig launchers and receivers,
- b. Individual tie-in points of each well with main header(*to be included in well head assembly*),
- c. Gathering Facility(*at some fields the tie-in points of each well (number of well tie-in may vary from 05-15 and varies from 06-50 wells in large fields) has been gathered at one point*)

iii. Oil / Gas Processing Plant Facilities, Assets, equipment's etc:

These include ALL KIND OF PRESSURE and Atmospheric VESSELS, tubes and piping circuits but not limited to following;

- a. Separators of various dia - 30-48" etc – two phase / three phase, Knock-out Vessels, and Filters,
- b. DCS/Digital/Pneumatic and/or PLC based SCADA system for process monitoring & controls
- c. Various type of pressure vessels (various dia, length & material),
- d. Heat exchangers, Regenerators, Gas heaters, Suction scrubbers, Chillers,
- e. Distillation Towers / Fractionators, Absorbers, Line heaters, Re-Boilers, Multi-Stage Pump Casing,
- f. Above-ground storage tanks of various capacities i.e. 3000, 4000, 5000, 6000, 8000, 10000, 12000, 20,000, 40,000 Bbls.
- g. All the exposed, buried and/or insulated, pipe lines network of the processing plant having different length, diameter (2", 4", 8", 10", 12", 14", 16", 20", 24", 26", 36", 42", 48", etc.) and grade of material, etc.

3. Scope Wise WORK PACKAGES

(Group: A:I; deliverables follows) The scope for the WORK PACKAGES is as follows:

**Group A: Wellhead sizing, design and construction package**

Pack A1

The scope includes design and development of construction package for all surface facilities installed at well site and tie in.

Pack A2

The scope includes design and development of surface facilities installed at well site and tie in as per deliverables under A2.

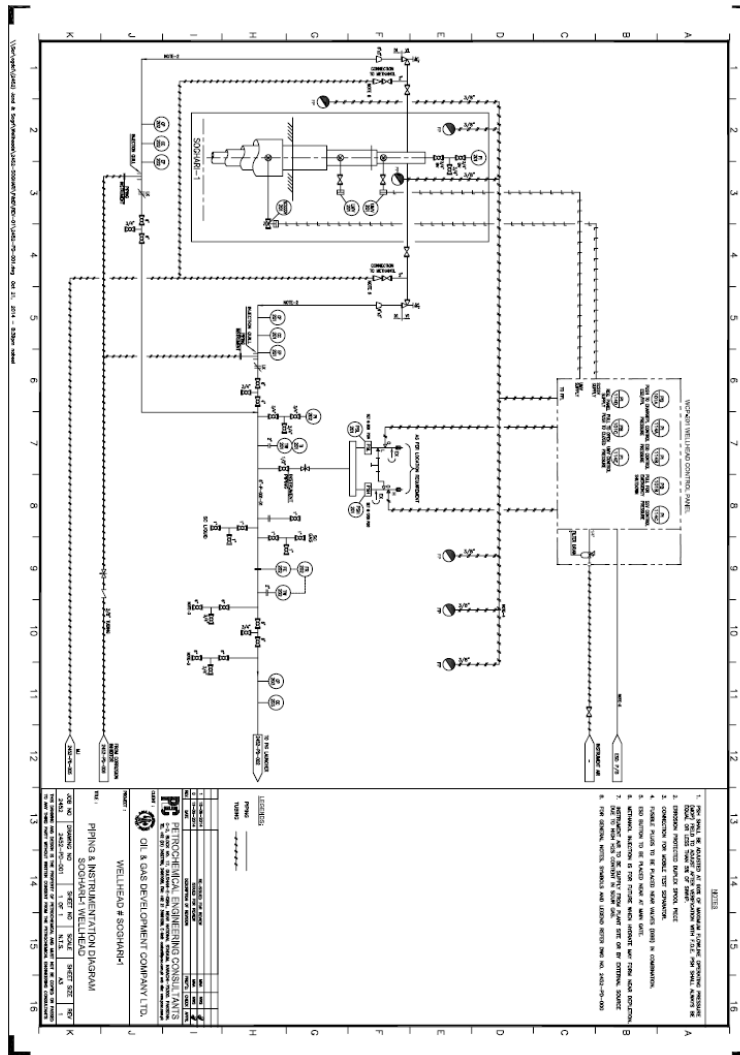

**Group B: Flowline SURVEY Design Package**

- a. One job comprises of survey upto 50 kms of pipeline.
- b. Pipeline survey upto 50kms and any more or less actual length than 50kms; pro rota based unit rates would prevail.
- c. Elevation profile / topographic survey(with at least 5 sectional information) as per best engineering practices and attached survey sheet (with five sectional information, as per GUIDELINES and sketch attached).

**Group C: For PIPELINE DESIGN & CONSTRUCTION Package**

- a. One job comprises upto 30 kms of pipeline.
- b. Pipeline survey upto 30 kms and any more or less actual length than 30 kms; pro rota based unit rates would prevail.
- c. The scope includes design and development of construction package for pipeline starting from Pig Launcher System and terminating at Pig Receiver System.
- d. Construction of pipeline, tie-in and pipeline safety system design and drawings for pipelines. as per best engineering practices

**Group D: As Built Drawings Packages**

- a. As built for
  - D1:** Upto 50kms survey for pipeline would be quoted in this package with wellheads (included in this cost) as lump sum. If pipeline length exceeds; than unit kms rate on pro rota basis of 50 kms would be charged; and

**D2:** Upto 20 wellheads as built cost for additional wellheads packages; than unit rate on pro rata basis would be charged on minimum basis.

- b. Details five section details as per site survey with material band; alignment survey, sheet markers, well alignment (nearby) and reference section, as per attached reference survey sheet details.
- c. With digital AutoCAD drawings in 4 CD copy sets

**Group E: For HAZOP & Process Safety package**

- a. HAZOP study with OGDCL approval on CV submitted for each project
- b. Third party experienced (25 years work for HAZOPs), independent HAZOP Chairman
- c. At least 15 HAZOP experience
- d. At consultant's office for three days for OGDCL engineers.

**Group F: Green Field Basic Engineering/Feasibility Studies**

This group is for upcoming marginal fields/process plants or new small/medium sized fields/process plants. Following is scope of work for the deliverables.

1. Development of Basic Engineering Package.
2. Feasibility Studies.
3. Process/Concept Selection.
4. Development of Process Simulation Model
5. Process Design Basis
6. Development of PFD's, UFD's along with Heat & Material Balance.
7. Development of P & IDs.
8. Budgetary Cost Estimates
9. Engineering Calculations & Results.

**Group G: Brown Field Modifications/Process Studies/Re-vamps/De-bottlenecking**

This group contains existing gas processing plants e.g. KPD, Qadirpur, Dakhni, Uch, Sinjhor, Chanda/Mela, Nashpa, etc. Following is scope of work for the deliverables:

1. Development of Basic Engineering Package
2. Development of Process Simulation Models
3. Process Design Basis
4. Development/Up-dating of P & IDs.
5. Development of PFDs, UFDs along with Heat & Material Balance.
6. Brown-field Modifications/ Process Studies/De-bottlenecking/Re-vamps/Retrofits.
7. Adequacy Check of Process Equipment's /Process Utility Lines/Piping, etc.
8. Evaluation of Process Efficiencies.
9. Updating of Operating Manual of Gas Processing Plants/Systems/Units.
10. Preparation of BOQ's for any modification job.
11. Development of Piping Isometrics.
12. Sizing/Validation of Pressure Relief valves.
13. Process & Control Philosophy, ESD, F&G.
14. Development of Data Sheets for Process/Mechanical/E & I.
15. Equipment Structural and Foundation Design.
16. Budgetary Cost Estimates
17. Engineering Calculations & Results.
18. Support in Process Optimization.

**Group H: Safety/Miscellaneous.**

This group applies to any Safety/Miscellaneous Studies for existing/upcoming gas processing plants.

1. Process Safety Studies/HSE Case.
2. Risk Assessment/SIL Studies
3. Support in Root Cause Failure (RCFA) of any incidents/equipment/process systems/failures/upsets.

**Group I: For Project Management & Inspection Services**

1. The scope include RT inspection / review of welding inspection contractor by qualified Level II RT (3 years post qualification, continuous work experience) with PMI certified (One year post qualification work experience) inspector
2. Daily welding and site progress reporting from site for a period of four months for pipeline construction & wellhead / tie-in sites
3. Monthly rates for up to four months are to be quoted for above qualified inspector and payment would be made on pro rata basis for any period over or under four months of mobilization.
4. Payment in such cases would be made on lowest basis, as above.
5. Inspector CV are to be submitted in accordance with this document at the project execution time, as informed by OGDCL.

**Group J: For Additional Works**

Additional works as per FINANCIAL TABLE PART B with manpower rates.

**Project TIMELINE:**

- a. Basic design package must include Conceptual Study, **one week prior** to the Kick Off meeting, but **not later than 15 working days** from the date of issuance of service order/work order by OGDCL.
  - b. Client's approval would be done after the 1) submission of Basic Design Package as per work order / service pack, 2) Project Schedule for the Deliverables and milestones (in MS Project or equivalent form) and 3) Kick-Off Meeting.
  - c. Design package would be approved by the OGDCL within **15 days** from the receipt of complete design engineering pack after the Kick-Off meeting.
  - d. Complete deliverables as per this document must be submitted by the consultancy company **in thirty working days period** maximum (after the approval of Basic Design Package).
4. OGDCL Desired Deliverables List for Group A, B, C, D, E: (to be attached in Final Folio/Dossier)  
Each project / Group case would be completed with CD (2 in numbers; one to HEAD OFFICE and other to the FIELD LOCATION through courier) are also required for digital record.  
In each six months period External Hard Disk in duplicate (1TB, in two numbers) would be updated for project, documents, and drawings updates through courier to OGDCL Head Office.

**FOR GROUP A**

**FOR GROUP A1**

- a. PROCESS Package
  - a. Design Basis
  - b. Hydraulic Study
  - c. P&ID
  - d. PFD
  - e. Data Sheets
  - f. Specifications
  - g. BOQ
  
- b. MECHANICAL Package
  - a. Plot Plan
  - b. Piping Layout
  - c. Isometric
  - d. Stress Analysis
  - e. Data Sheets
  - f. Specifications
  - g. BOQ
  - h. Scope of Work for construction.
  
- c. CIVIL Package
  - a. Plot Plan
  - b. Civil drawings
  - c. Data Sheets
  - d. Specifications
  - e. BOQ
  - f. Scope of Work for construction.
  
- d. Electrical & Instrumentation Package
  - a. P&ID
  - b. ESD / Safety System
  - c. Data Sheets
  - d. Specifications

**FOR GROUP A2**

- a. PROCESS Package
  - a. P&ID
  - b. PFD
  
- b. MECHANICAL Package
  - a. Plot Plan
  - b. Piping Layout
  - c. Isometric
  
- c. CIVIL Package
  - a. Plot Plan
  - b. Civil drawings
  
- d. Electrical & Instrumentation Package
  - a. ESD / Safety System

**GROUP B & D**

As per SURVEY GUIDELINES As per survey deliverables and guidelines provided in the document. Sample with bands: 5

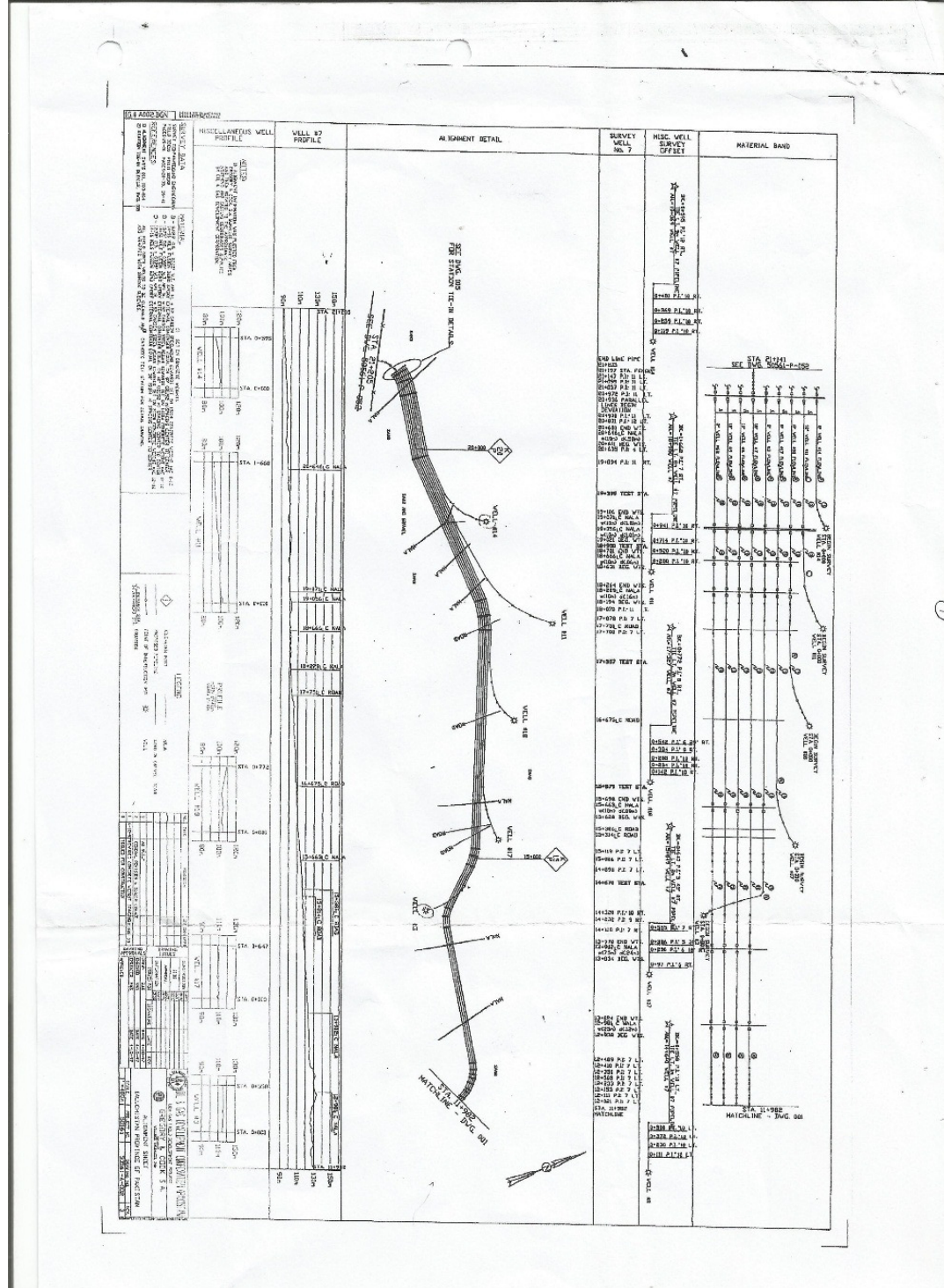

GUIDELINES DETAIL SURVEY WORK (Group B & D)

SCOPE OF WORK for well location, pipeline route, ROW for pipes during construction and operations and tie-in with alternate route for pipes with at least one included in package based on I/c Production Facility recommendation of respective area/field of OGDCL.

## **1.0 GENERAL**

The survey work shall be carried out with respect to the following broad guidelines:

- i. Coordination and levels of the nearest existing Road(s).
- ii. Descriptions of Terrain of the survey area.
- iii. Coordination and alignment of existing features falling within 50-m (fifty meters) of survey area like boundary wall of other plots, towers for high-tension line, electricity plots, all buried and exposed utility lines, hills and rock etc.
- iv. Survey of all manmade and naturally occurring drains, nalas, ditches etc, indicating the direction of flow.

## **2.0 DETAIL SURVEY**

The detail survey of the selected site shall provide sufficient recorded data and information required for plotting of grading and drainage plans, establishing the finished ground elevations, acquisitions/purchase process of plots and prepare material estimates etc.

### **2.1 HORIZONTAL CONTROL**

The coordinates of control points will be given in time of national grid and shall be connected to survey of Pakistan (SOP) GTS Control point marker will be constructed.

### **2.2 VERTICAL CONTROL**

Vertical Control Station shall be established and tied to the nearest Survey of Pakistan (SOP) GTS and Benchmark \Datum.

All bench Marks including Temporary Bench Marks shall be established beyond the area of construction in protected places.

### **2.3 SURVEY FOR SELECTED AREA**

The detail survey of the proposed site shall be carried out to establish the boundary limits / bearings of the site boundaries with respect to true North the location of plant area and the ground profile etc.

At the start of detail survey the contractor shall construct a permanent bench Mark at an appropriate location, within the selected site. The coordinates and levels of Bench Mark shall be tied with the Survey of Pakistan (SOP) GTS and Datum.

The survey contractor shall record accurate measurement of plan and profile, including but not limited to following.

- i. Precise demarcation of the selected site from the Revenue Maps and marking on SOP and Revenue maps showing survey numbers and property lines (The SOP maps and revenue maps will be provided by Contractor/surveyor).
- ii. Elevation with reference to Benchmark at every 10-m (ten meters) grid interval on both axis and at every change in slope depict a real profile of the land.

- iii. Any permanent structure / feature within 50-m (fifty meters) from the plot boundary shall be measured and shown on the drawings.
- iv. Fixing wooden pegs at 50M (fifty meter) interval and each change in direction of plot area.
- v. Installation of permanent makers/posts at 100-m (hundred meters) interval and at each change in direction of plant area.
- vi. Horizontal distance along with the boundary limit of plant area.
- vii. Topographic and contour survey.
- viii. Features like flood problem bunds, channels, drain / nalas and hills etc, which could influence the design and / or construction, shall be noted.
- ix. Special attention shall be given to Rain watercourses passing through or within 50-m (fifty meters) from the plot limits. The contractor shall record the rain watercourse bed contours 100-m (hundred meters) upstream and 100-m (hundred meters) downstream from the plot boundary limits.
- x. Spot levels within the distance of 20-m(twenty meters) outside the plot limits.

### 3.0 **ACCURACY**

Survey contractor shall take every possible care in producing most accurate results. The minimum standards of accuracy to be attained shall be as under.

Traverse line	:	1:50,000
Angles observation	:	5 secs, 360 degree system.
Spot levels	:	0.01 meters.

### 4.0 **DOCUMENTS**

All documents i.e. maps, detailed drawings etc, prepared by the survey contractors shall be submitted to OGDCL in original along with four copies each of the final survey maps and reproducible transparencies, including but not limited to:

4.1 The levels and field data shall be provided on electronic files and submitted in CD-ROM suitable for use on desktop computers. The CD-ROM should be readable in AutoCAD release 2000 or latest (under windows). Field books shall be submitted where required.

4.2 Survey of Pakistan (SOP) map duly marked with selected site with necessary updating for important

Developments like new villages/towns, roads, etc. subsequent to original SOP map preparation, scale:1:50,000(SOP maps will be arranged by the surveyor).

4.3 Overall layout of the area showing selected site and existing constructions/features, showing coordinates and bearing of boundary limits, location of Benchmark and related information, ground elevations at 10 meter grids etc. provided in AO size on scale 1:1000.



4.4 Plan of the selected location for plant area showing coordinates and bearing of boundary limits, location of bench mark and related information ground elevations at 10-meters grids etc, provided in A-1 size, appear on Scale 1:500.

4.5 Any other documents, which may be required or may prove useful in design or construction of the said site.

4.6 Overhead electricity & telephone lines running along or crossing the selected site route shall also be clearly indicated on maps / drawings.

## **5.0 DEMARCATION OF SITE**

Demarcation of selected site shall include but not be limited to the following.

### **5.1 WOODEN PEGGING**

The boundary limits of the surveyed area shall be physically marked by fixing 2''x2''x24'' wooden pegs into ground (18'' deep) at 50m (fifty meter) interval.

### **5.2 BENCH MARK**

Contraction and installation of permanent Horizontal and vertical control Bench Mark at selected site or is directed by OGDCL .The Bench Mark shall be correlated and tied with survey of Pakistan SOP datum. The Reduce level shall be expressed in meters.

### **5.3 PERMANENT MARKERS**

Permanent markers made in reinforced concrete with dimensions 200mmX200mmX1000mm long with a square of 600mm X 150mm thick shall be provided, installed white washed and marked and shall be erected at every 100 Meters, and at all points of instructions (PI) along boundary limit of selected location for plant area.

## **6.0 APPROVALS**

Upon completion of fieldwork, the contractor shall prepare first issue of survey drawings and submit two (02) sets of the same for review approval and selection of plant area by OGDCL. The survey drawings will be in accordance with graphic format approved by OGDCL.

## **7.0 DELIVERABLES**

The survey Contractor shall provide the following deliverables.

### **7.1 SURVEY DRAWINGS**

The survey Contractor shall submit four (04) copies of approved survey drawings along with original reproducible transparency.

### **7.2 Maps**

- i.** Four (04) copies of SOP map duly marked with approved layout of selected site
- ii.** Four (04) copies of Revenue maps duly marked with approved layout of selected site.

(NOTE: The SOP maps and Revenue maps will be provided by contractor/supplier).

### **7.3 SURVEY NOTES AND DATA**

One (01) original and two (02) copies of the following shall be submitted.

- i. Level and field data.
- ii. Survey notes/data.
- iii. List of Bench Marks.
- iv. List of Markers/Posts.
- v. Coordinates and elevation of control point.
- vi. Control and leveling computations.

### **7.5 SURVEY Deliverables**

1. Survey would be done through control point mentioned in the guidelines, with all the Survey of Pakistan and Revenue maps being purchased by the contractor at its cost. SoP & Revenue maps would be handed over to OGDCL site team/location in-charge before final invoice.
2. The flow lines survey must be supported by Google Earth posts on files and provide with CD (3 No.'s in all) to OGDCL (focal contact person for the project) before raising invoice for review and due concurrence to the field.
3. Field survey on A0 size on scale 1:1000 for layouts and ROW pipeline surveys would be provided hard prints (two sets: one addressed to FIELD and one addressed to Head Office) before final invoice.
4. Provide two (02) sets of soft copies for all documents / drawings. All soft copies shall be in editable format (Word, Excel, Auto CAD).
5. Each set shall comprise of two compact discs. The contents of Disc-1 shall include survey drawings and Scanned maps (SOP & Revenue) whereas the contents of Disc-2 shall include the remaining data/documents.

### **GROUP C**

- a. Pipeline Hydraulics Analysis
  - b. Pipeline Thickness calculation
  - c. Pipeline Flexibility Analysis
  - d. Elastic bend radius calculation
  - e. Design of Pipeline Anchor Block
  - f. Detailed Design of Tie in
  - g. Piping and Civil Bill of Material for Tie in
  - h. Development of P&ID for Tie in
  - i. Development of Piping Isometrics for Tie in
  - j. Scope of work for Pipeline Construction Contractor
  - k. Scope of work for Tie in Works at
  - l. Preparation and Submission of Pipeline construction Package
5. Payment and INVOICING:  
The final invoices with all the applicable tax breakup, dates, work order / service order description and documents verification receipt (for deliverables); would be submitted at Manager (Production Facilities) OGDCL Head Office Islamabad after
- a. Counter signed by the consultant's focal engineer in each case/invoice,
  - b. the invoice verification from respective field manager and production Incharge (or nearby operative location of OGDCL),
  - c. Copies submission of relevant standards as per application / kick off meeting and discussion,
  - d. IFC, tender and/or procurement package,
  - e. A set of Standard Operating Procedure,
  - f. Record of minutes and emails in final dossier,
  - g. the submission of deliverables including all packages as above, and
  - h. The meetings including PROCESS HAZOP/HAZID (if required) and Project Close Out.
  - i. Invoice would be cleared as per above after its submission.

The invoices would be cleared at OGDCL Head Office Islamabad after the invoice verification from respective field (or nearby operative location of OGDCL) after the submission of deliverables.

6. OGDCL Focal Contact Person Details:  
Manager (Production Facilities)  
Petroleum Engineering & Facilities Department  
8<sup>th</sup> Floor, OGDCL House, Jinnah Avenue  
Blue Area, Islamabad - PAKISTAN  
Phone: 051 92002-2815, 2816& 2849.

OGDCL reserves the right to terminate this contract with one month advance notice to the consultant company without assigning any reasons as a right.

7. Evaluation of the bid
1. FINANCIAL Evaluation would be carried on the each Group (**A:J**) basis and award of each Group would be made to the lowest in each GROUP basis.
  2. The FINANCIAL TABLEs Part A & B deal with the scope enumerated at WORK PACKAGES **A:J**. While the work to be executed by the consultant that is not covered under the PART A, is mentioned and covered under PART B of the FINANCIAL TABLE. However both tables A & B would be part of financial evaluation.
  3. The Groups work would be quoted on LUMP SUM basis, including all logistical costs, taxes and liabilities as per FINANCIAL TABLE Part A& B.
  4. FINANCIAL table would be duly filled in for all the activities. Any leftover or black work package would be deemed service FREE of Charge by the CONSULTANT for the purpose of this SERVICE AGREEMENT and Contract.
  5. Registration of company with PEC (1212, 1213 and 1235) and SECP as a recognized engineering consultant company to be provided through certifications therein.
  6. In case of any foreign consulting company is interested in this bid; a proper JV agreement with a PEC/SECP registered Pakistani (1212, 1213 & 1235) must be attached with the Technical Bid.
  7. A surveyor company can also apply as part of GROUP B & D (both or any) activity only with 1235 PEC certification with required manpower and work experience.
  8. The contract award would be on the basis of lowest value on GROUP wise basis i.e. **A:J**.
  9. The JV agreement in case of foreign company consortium with Pakistan based Company must include a shared set of responsibility matrix and liability clause and must be signed on Rs. 1,000/- (Rupees One Thousand Only) Judicial Stamp Paper with signatures from the City Magistrate in which the Pakistan based company has its registered office.
  10. CV of all the engineers / associate engineers showing complete experience with project profiles; on the Company payroll to be provided with valid PEC certificates in the bid proposal.
  11. List of last ten years of engineering consultancy projects / studies to be provided with proposal.
  12. Air tickets (only for items under FINANCIAL table # B) would be paid under final invoice on actual costs (tickets with boarding passes have to be attached in the name of the traveler for due dates). Tickets costs are not included in the evaluation costs.
  13. Hotel charges quoted are part of the overall cost and included in evaluation.
  14. All the applicable relevant federal, provincial, regulator, statutory taxes/fees/charges/GST/Service Fee etc are to be quoted as per law in the financial bid by the consultant company. OGDCL will consider the quoted prices inclusive of all the fees/taxes/etc.
  15. Any new imposition of fees/taxes would be charged accordingly over the contract / service agreement would be on account of bidder before the project finalization (submission of final invoice). Consultant would have to pay and bear this impact the fee/tax accordingly on its own.
  16. At the bid submission time, the bidder will only submit technical bid showing COMPLIANCE of the FINANCIAL TABLE without any financial numbers / figures therein; while following the other pre-requisites of the TECHNICAL proposal. However the FINANCIAL BID will be submitted in a separate sealed envelope having FINANCIAL TABLE duly completed in all respect.

17. During clarification/evaluation (if any); no price adders (addition/deletion) in the FINANCIAL Bid would be allowed. FINANCIAL bids are not to be changed in any case, after submission under this tender.

8. BOARDING, LODGING, TRANSPORTATION ETC.

**Accommodation:**

OGDCL will provide boarding and lodging facilities for professionals of the contractor at field facilities / camp as on need basis. The contractor's professionals will be accommodated according to the seniority. All graduate engineers shall be accommodated in officer's camp where as supervisors and technicians and other staff will be provided accommodation in assistant/staff camp. Boarding & lodging as per suitable arrangement would be on account of OGDCL head at site locations/field.

**Food/Messing:**

Food will be provided to the contractor's professionals at field from respective messes in which they will be accommodated on OGDCL account and cost.

**Transportation:**

Transportation of personnel's from nearby airport / railway station to OGDCL location / field shall be provided by OGDCL to the limited team of contractor. Within OGDCL field area/location; transportation from the nearest airport (or railway station as applicable) would be the responsibility of OGDCL. In field/location movement for consultancy (if required) and survey/as built exercise; would be the OGDCL responsibility.

9. TECHNICAL TABLE

With valid certifications for **continuous dates** w.e.f FIRST registration to ascertain number of valid years till latest

SR. #	DESCRIPTION	CRITERIA	OBTAINED MARKS
1	Registration with (marks): 1) PEC under engineering consultancy for (x9) i: Projects in Petrochemical (1212), (x3) ii: Oil and gas pipelines, development, storage, Transmission and distribution systems (1213) (x3) and iii: Survey (1235) with valid certifications (x3) 2) ISO 9001 (x2) 3) ISO 14001 (x2) 4) OHSAS 18001 (x2) with valid certifications for <b>continuous dates</b> w.e.f FIRST registration to ascertain number of valid years till latest	<i>For each of the 6 certificates:</i>  Over 5 years each (full marks)  4 to 5 years each (half marks)  Under 3-4 years each (quarter marks)  Under 3 years each (1/10 marks only)	  15  7.5  3.75  1.5
2	Number of Projects with consultancy studies with PROJECT CAPEX in last 5 years. Project capital of USD million or others are based on project CAPEX and not the study value.  Each Project Name, with company address, focal person email mobile contact with Service Order(s) copies in the name of bidder must be provided.	Over 5 projects over one million US\$ each  Over 5 projects over US\$ 0.5 to 1.0 million each  Under 3-5 projects over US\$ 0.25-0.49 million each  Under 3-5 projects of US\$ 0.1-0.249 million each.	25  15  07  02

3	Only VALID and Current; pre-qualification/registration with Pakistan based E&P companies on rate running / call-off/ annual / biennial/ or term basis. Contracts/work orders attested copies are required to verify the same and must be submitted with proposal. <u>Only current and valid contracts are to be considered.</u>	5 and over 5 companies & current Only 3-4 companies and Only 1 to 2 only None	20 10 5 0
4	Lead Engineers (PROCESS/MECH/CIVIL/E&I) and/or LEAD SURVEYOR with 8years' experience with PE status. Each Engineer would be given 3 marks (08 x 3 = 24 max) with alternates in each field. CV's needed.	With alternates in each field double marks.	w/ alternates 24 w/o 12 No lead - 0
5	Process Engineering Head and/or HEAD SURVEYOR is to provide CV and detailed profile. Upstream oil & gas experience is a must and it should be reflected over in the work portfolio.	25 years experience 07-25 years Under 07 years and over 3 years Under 3 years	16 08 04 01

Note: Minimum Qualification Marks are 70 out of maximum for financial evaluation. The technically responsible (equal to more than 70 marks under technical) and lowest in the financial table would be awarded the bid/contract for the initial period of three years.

#### FOR Group I ONLY Project Management & Inspection Services

#	Qualification for Company for Group I	Reply
1	RT Level II (post 3 years) and PMI (post 1 yr) qualified Inspectors (min. 5 CV's required)	

OGDCL intends to have competitive bidding and small scale setups, and/or individuals involved in survey activities should also bid ONLY for Groups B & D. Registered companies; participating in others groups (excluding groups B & D) should not fill the following one table.

SURVEYOR's QUALIFICATION (as an independent bidder) for Group B&D			
1	Survey (1235) with/without valid certifications or SURVEY OF PAKISTAN certification for personnel	10	
2	<u>For Survey &amp; As Built groups (B &amp; D groups) Company Bid only; the corresponding survey PROJECT cost is in Pak Rupees.</u>	20	
3	Survey personnel's / technicians list and CV with company to be provided	20	
4	NTN number (05) Equipment for survey /list with make model and country to be provided (05)	10	
5	Minimum of 100 kms of pipeline route survey to be provided with CLIENTS and Project name, year.	25	
6	Current projects in hand and last projects completed in 2016 with details: 1. Client 2. Project 3. Cost 4. Scope 5. Role 6. Year (months/year)	15	

Note: Minimum Qualification Marks are 60 out of maximum for financial evaluation.

10. FINANCIAL TABLE

**PART A:** Agreed Fixed Rates in Consultants' Contract for each Work Package separately  
(A:J):

Sr. #	Packages Code	SCOPE	Qty of jobs Q	Package Group: Lump sum Cost (M)	Taxes (all inclusive) (N)	TOTAL O = (M + N)	FINAL TOTAL (R) = (O x Q)
1	A	Wellhead sizing and construction package					
		A1 =	10				
		A2 =	15				
2	B	Flow line SURVEY Design Package:	15				
3	C	For PIPELINE CONSTRUCTION Package	15				
4	D	As Built Drawings Packages					
		D1 (For pipeline )=	10				
		D2 (For wellhead ) =	10				
5	E	For HAZOP and Process Safety Study	10				
	F	Green Field Basic Engineering/Feasibility Studies	10				
	G	Brown Field Modifications/ Process Studies /Re-vamps / De-bottlenecking	10				
	H	Safety/Miscellaneous	10				
	I	For Project Management & Inspection Services	30				
6	J	For Additional Works (from PART B) Value Y	PART B table				
7		Subtotal: X for PART A					

**Note: 1) The above prices / rates should be inclusive of all applicable taxes, levies, duties etc except Provincial Sales Tax on Services. Provincial Sales Tax on Services if applicable will be paid /reimbursed by OGDCL.**

**2) These \* are best estimates for three (or contracted period) years OGDCL projects and job numbers may vary within contract financial limits.**

**Total:** \_\_\_\_\_

**In words TOTAL X (A:F):** (In Pak Rupees: \_\_\_\_\_ )

**Authorized SIGNATURE and**

**COMPANY SEAL/STAMP**

TOTAL FINANCIAL BID worth including FINANCIAL Part A (including TABLE B):

<p><b>GRAND TOTAL (for PART A)=_____ in words ( _____ )</b> <b>for overall SCOPE (packages A:F)</b></p>
---

Authorized Signature \_\_\_\_\_ with stamp Date: \_\_\_\_\_

Name: \_\_\_\_\_

Title: \_\_\_\_\_ and official stamp seal on Company's letterhead

**FINANCIAL Evaluation would be carried on the each Group (A:F) basis and award of each Group would be made to the lowest in each GROUP basis.**

**PART B: For any additional work/activity which is not covered under the above WORK PACKAGES (in Pak Rupees) to be part of financial evaluation:**

Name & Position	Years of relevant experience	Office based Man-days Rates (8 hr/DAY)	Site Charges per Day (24 hr/day)	Station to Location (air ticket ECONOMY Class)	Hotel charges on daily basis (incl. daily rates) other than field	Applicable taxes (as per GoP & Provincial Tax Laws)	Sub Total P	QTY (DA Ys) Q	Grand Total R =- P x Q	
Project Manager	At least 12 years, PEC PE status			As per actual, not part of evaluation.				30		
Lead ENGINEER Mech/E&I/ Civil/Piping /HSE/ Process/Project	08 years and more, PEC PE status								30	
Resident Engineer (Mech)/ E&I/Civil/ Piping/HSE/ Process/ Project	At least 3 years experience with PEC PE status								30	
Assistant Engineer	PEC RE status								30	
Surveyor for flow lines and plant (including as built)	At least 15 years of field experience			This travel head must be included lump sum cost quoted in unit rates. No payment on this account.				30		
Senior Supervisor	With over 15 years of experience								30	
Supervisor	With over 10 years of experience								30	

Total (Y) is SUM (R): \_\_\_\_\_

TOTAL Y : \_\_\_\_\_

In words: ( \_\_\_\_\_ )

**Notes:**

A) The above prices / rates should be inclusive of all applicable taxes, levies, duties etc except Provincial Sales Tax on Services. Provincial Sales Tax on Services if applicable will be paid /reimbursed by OGDCL

B) The site visit by all the above positions have one mobilization and one demobilization date. OGDCL will consider the work charge days of only one day (instead of one MOB and one DEMOB dates) and would pay one day against MOB and DEMOB on account of to and from field site movement.

C) Payment for above mentioned additional; work / activity will be made as per actual utilization. Only economy class return air tickets cost would be considered for payment on actual basis and this would not be part of financial evaluation. The cost of the same will be paid as per actual. The above quoted rates / Prices should be inclusive of all applicable taxes, levies, duties, charges, etc except Provincial Sales Tax on Services. Provincial Sales Tax on Services where applicable will be paid / reimbursed by OGDCL.

11. COMPLIANCE SHEET

Bidder is to provide SECTION WISE documents in the following order in its BID for clarity:

Sr. #	Description	Compliance by the Bidder
1.	Registration with PEC under engineering consultancy for Projects in Petrochemical (1212); Oil and gas pipelines, development, storage, Transmission and distribution systems (1213); and/or Survey (1235) with valid certifications for <b>continuous dates</b> w.e.f FIRST registration to ascertain number of valid years (as per applicable group)	
2	Registration with 1) SECP and 2) FBR for Engineering Consultancy Services with valid certifications for <b>continuous dates</b> w.e.f FIRST registration to ascertain number of valid years	
3	In case of Survey ONLY; Compliance of Training of Surveyor(s) from <u>SURVEY of Pakistan</u> (with certificate copy) instead of above registrations.	
4	Total Scope compliance (signed of all of these pages) with authorized sign & stamp	
5	CV's of all the involved teams for process, civil, mechanical, E&I and Survey	
6	Technical engineering and professional software's used under CIVIL/MECHANICAL/E&I and PROCESS separately (4 tables) with competency level and number of years of licensees with valid certifications for <b>continuous dates</b> w.e.f FIRST registration to ascertain number of valid years (waiver in case of SURVEY company ONLY)	
7	NTN certificate (FIRST and Valid) to ensure company STATUS for registration and INCEPTION	
8	Email domain in the name of COMPANY (YES/NO) if YES please provide	
9	Certifications for 1: ISO 9001 2: OHSAS 18001 and 3: ISO 14001 with valid certifications for <b>continuous dates</b> w.e.f. FIRST registration to ascertain number of valid years till latest. (waiver in case of SURVEY company ONLY)	
10	Technical table compliance in FULL	



11	Financial table compliance in FULL (in separate envelop with the financial bid)	
12	Reporting (daily email with % progress) with weekly updates and final dossiers with all deliverables to be confirmed (YES/NO)	
13	Similar work profile in Pakistan with Companies Service Order(s) to be shared for evaluation criteria for <b>CURRENT &amp; VALID in hand projects ONLY (2016 and onwards only)</b>	
14	Process Engineering Support / Engineering Lead to be provided with CV and detailed profile as per Criteria (waiver in case of SURVEY company ONLY)	
15	Compliance to entire OGDCL scope by submitting signed & stamped copy of entire technical scope (as above)	
16	Three years financial AUDITED reports (waiver in case of SURVEY company ONLY)	
17	Last three years Income Tax paid with certificates and cost paid to national exchequer	
18	Last three years active bank statements ( <b>duly signed and stamped in the name of bidding company by the banker</b> )	
19	Be on FBR's ATL list for the registered company in the current year of tender, certificate to be attached.	
20	The bidder / consultancy company must have a VALID office in PAKISTAN.	
21	<b>NTN number to be provided with valid certificate copy</b>	
22	<b>Any deviation to above / scope (if any) in detail. If not mentioned here; it would be deemed that 100% compliance with OGDCL scope / technical document is followed in totality.</b>	

**BID BOND**

Oil & Gas Development Company Limited,  
OGDCL House, Jinnah Avenue,  
Blue Area, Islamabad.

Guarantee No.....  
Date of issue.....  
Date of expiry .....

Amount.....

Dear Sir,

In consideration of M/s.....  
herein after called "THE BIDDER" having submitted the accompanying Bid with  
reference to OGDCL tender enquiry No. **PROC-SERVICES/CB/PE&FD-  
3056/2017** and in consideration of value received from (the Bidder above), we  
hereby agree to undertake as follows:-

1. To make unconditional, immediate and forthwith payment of the sum of  
**PKR 2,600,000/- PAK RUPEES TWO MILLION SIX HUNDRED THOUSAND**  
**ONLY upon** your FIRST and SIMPLE written demand without further recourse,  
question, query, deferment, contestation or reference to the bidder, account  
party or any other person in the event of the withdrawal of the aforesaid bid by  
the BIDDER before the end of the period specified in the Bid after the opening  
of the same for the validity thereof or if no such period be specified, within 210  
days after the said opening or if the Bidder, having been notified of the  
acceptance of his bid by the Company during the period of bid validity:
  - i. Withdraw their bid during bid validity.  
OR
  - ii. Fails to provide performance bond/or advance bank guarantees.  
OR
  - iii. Submit forged document in support of their bid.  
OR
  - iv. Fails to execute contract as per terms of contract.  
OR
  - v. Fails to supply the short/wrong shipped items
2. To accept written demand from you as conclusive, sufficient and final  
evidence of the existence of a default of non-compliance, breach or  
default as aforesaid on the part of the BIDDER and to make payment  
immediately and forthwith upon receipt of your FIRST and SIMPLE  
written demand.
3. No grant of time or other indulgence to, or composition or arrangement  
with the BIDDER in respect of the aforesaid Bid with or without notice to  
us shall affect this Guarantee and our liabilities and commitments  
hereunder.
4. This is an independent and direct obligations guarantee and shall be  
binding on us and our successor in-interest and shall be irrevocable.
5. The Guarantor Bank warrants and represents that it is fully authorized,  
empowered and competent to issue this guarantee.

**Yours faithfully,  
(BANKERS)**

**Note: Bid Bond/Bank Guarantee/Security will not be acceptable with the  
banks whose Market Price per share is quoted below the Par Value at the  
Stock Exchange**

**PERFORMANCE BOND/BANK GUARANTEE**

Oil & Gas Development Company Limited,  
OGDCL House, Jinnah Avenue,  
Blue Area, Islamabad.

Guarantee No.....  
Date of issue .....  
Date of expiry .....  
Amount.....

Dear Sir,

Ref: Our Bank Guarantee No. \_\_\_\_\_ in the sum of  
\_\_\_\_\_ Account \_\_\_\_\_ Amount \_\_\_\_\_ of  
Contract/Job \_\_\_\_\_

In consideration of you having entered into contract No.  
Dated \_\_\_\_\_

with \_\_\_\_\_ called Contractor and in consideration of value received  
from CONTRACTOR, we hereby agree and undertake as follows:

1. To make unconditional, immediate and forthwith payment to you as called upon of an amount (equivalent to 10% of total contract value in Pak Rupees) on your written FIRST and SIMPLE demand without further recourse, question, query, deferment, contestation or reference to CONTRACTOR or any other person, in the event of default, non-performance or non-fulfillment by CONTRACTOR of his obligations liabilities, responsibilities under the said Contract of which you shall be the sole and absolute judge.
2. To accept written demand from you as conclusive, sufficient and final evidence of the existence of a default or breach as aforesaid on the part of CONTRACTOR and to make payment immediately and forthwith upon receipt of your FIRST and SIMPLE written demand.
3. To keep this Guarantee in full force and effect from the date hereof until..... from the date of contract execution / mobilization Notice.
4. That no grant of time or other indulgence to, amendment in the terms of the contract by Agreement between the parties, or imposition of Agreement with contractor in respect of the performance of his obligation under and in pursuance of the said Agreement with or without notice to us, shall in any manner discharge of otherwise however affect this Guarantee and our liabilities and commitments there under.
5. This is an independent and direct obligations guarantee and shall be binding on us and our successor in-interest and shall be irrevocable.
6. This Guarantee shall not be affected by any change in the constitution of the Guarantor Bank or the constitution of the Contractor.
7. The Guarantor Bank warrants and represents that it is fully authorized, empowered and competent to issue this guarantee.

Authorized Sign for Issuing Bank

**Seal of the Bank**

**Note: Performance Guarantee/Security will not be acceptable with the banks whose Market Price per share is quoted below the Par Value at the Stock Exchange**

**BIDDING FORM**

Date.....  
Tender Enquiry No. ....

To  
Oil & Gas Development Company Limited,  
OGDCL House, Plot # 3013,  
Blue Area, Islamabad

Gentlemen,

Having examined the scope of work and Instructions to bidders of Invitation to Bids, the receipt of which is hereby acknowledged, we the undersigned, offer to supply the services (Nature of Service) to OGDCL in conformity with the scope of work and Instructions to bidders at the rates mentioned in our Bid Proposal or other such sums as may be ascertained in accordance with the said conditions.

2. We confirm that the terms and conditions given in the Tender Enquiry / Tender Documents are acceptable to us and if our Bid is accepted we shall execute a contract with OGDCL accordingly without any exceptions. We further confirm to commence service within .....days of the mobilization notice issued by OGDCL

3 We agree to validate bid unconditionally for the period of 180 days from the date of opening the same and it shall remain binding upon us and may be accepted thereof, shall constitute a binding contract between us.

4. We hereby certify that our Firm / Company / Local Agent is or has not been at any time during the past five years, involved in litigation, arbitration or any other unsettled dispute with OGDCL / JV Partners.

5. We further certify that all the contracts / orders placed on us by OGDCL / JV Partners have been executed timely and as per terms & conditions of the Contract / order without any unsettled dispute.

6. Until a formal Agreement is prepared and executed, this bid, together with your acceptance thereof, shall constitute a binding contract between us.

7. We understand that you are not bound to accept the lowest or any tender you may receive.

8. Our bid proposal do not contain any deviation or exceptions from the terms & conditions enunciated in the tender documents.

Dated this.....days of.....2017,

Name & Signature.....in the Capacity of.....

duly authorized to sign tenders for and on behalf of.....  
(Name of the firm in block capital Letters)

Address.....

Telex No.....Fax No.....Phone No.....

Witness

1. ....  
(Name) (Signature)

2. ....  
(Name) (Signature)

(On official letter-head of the bidder)  
To be signed by the  
Chief Executive of the  
Bidding company or a representative duly  
Authorized by board  
Resolution.

**INTEGRITY AND ETHICS UNDERTAKING**

We hereby commit and undertake to observe the following principles during our participation in the tender process and during the contract execution:

- i. That we will not directly or through any other person of firm, officer promise or give to any of the employees of OGDCL involved in the tender process or execution of the contract any gain, pecuniary benefit of facilitation payment in order to obtain in exchange any advantages of any kind whatsoever during the tender process or during the execution of contracts.
- ii. That we have not and will not enter with other bidders into any undisclosed agreement or undertaking either formal or informal to restrict competitiveness sort to cartelise in the bidding process.
- iii. That we will ensure that the remuneration of agents (if engaged) is appropriate and for legitimate services only.
- iv. That we will not use subcontracts, purchase orders or consulting agreements as means of channeling payments to employees of OGDCL.
- v. That we will not commit any offence under the Pakistan Penal Code, Prevention of Corruption Act or National Accountability Ordinance to achieve any advantage, gain or benefit during the tender process or the execution of the contract.

We further understand and acknowledge that any violation of transgression of the above mentioned principles will attract disqualification from the tender process and may also result in permanent exclusion from future contract award process.

We also accept and undertaking to respect and uphold OGDCL,s absolute right to resort to and impose such disqualification, debarment or execution.

For and on behalf of \_\_\_\_\_

Tender No \_\_\_\_\_

**Mandatory for participation in Bidding Process**

**A F F I D A V I T**  
**(To be attached with Technical bid)**

I, \_\_\_\_\_ S/o \_\_\_\_\_ aged \_\_\_\_\_ years \_\_\_\_\_ working as Proprietor/Managing Partner/Director of M/s \_\_\_\_\_ having its registered office at \_\_\_\_\_ do hereby solemnly affirm and declare on oath as under:

1. That I am competent to swear this affidavit being proprietor/one or the partners/ Director of M/s \_\_\_\_\_
2. That M/s \_\_\_\_\_ is a proprietorship/partnership firm/company is participating in tender process conducted by OGDCL.
3. That I hereby confirm and declare that none of my/our group/sister concern/associate company is participating/ submitting this tender.
4. That I hereby confirm and declare that my/our firm/company M/s \_\_\_\_\_ and my/our firm/group/company/ sister concern / associate company have not been black listed/de-listed any Institutional agencies/Govt. Deptt/ Public Sector Undertaking.
5. That there is no change in the Name & Style, Constitution and Status of the firm, after Pre-qualification.
6. That I further undertake that in case any of the facts contained above and in-our application is round other-wise or incorrect or false at any stage, my/our firm/company/ group/sister concerns/ associate companies shall stand debarred from the present and future tenders of the OGDCL.

(Signature of the Proprietor/ Managing Partner/Director with Seal)

DEPONENT

Verified at \_\_\_\_\_ on \_\_\_\_\_ that the contents of paras 1 to 6 of this affidavit are true and correct to best of my knowledge and no part of this is false and nothing material has been concealed or falsely stated therein.

(Signature of the Proprietor/ Managing Partner/ Director with Seal)

DEPONENT

(Signature & Seal of Notary)

**DATA SUMMARY SHEET**  
**(To be attached with Technical bid)**

**Following information must be stated categorically:-**

COMPLETE NAME, ADDRESS, EMAIL,  
PHONE & FAX NUMBER OF BIDDER

---

---

NAME, ADDRESS, PHONE, FAX NO &  
EMAIL OF LOCAL AGENT IN PAKISTAN (IF  
ANY

---

---

VALIDITY OF BID:

---

COMPLETION PERIOD:

---

BID BOND SUBMITTED BY

---

ADDRESS OF BANKER WITH AC  
COUNT NO & SWIFT CODE FOR L/C  
OPENING (WHERE APPLICABLE)

---

---

IN CASE OF JV PARTNERS (NAME OF  
LEAD PARTNER NAME OF ALL OTHER  
JV PARTNERS COPY OF JV  
AGREEMENT CLEARLY STATING THE  
RESPONSIBILITY OF EACH PARTY TO  
BE ATTACHED WITH THE TECHNICAL  
BID

---

NTN, GST & PST NUMBER (FOR  
PAKISTAN BASE COMPANY ONLY

---

ANNEXURE -F DULY ATTESTED BY  
NOTARY PUBLIC.

---

PROVINCIAL REGISTRATION NUMBER

---

**DATA SUMMARY SHEET**  
**(To be attached with financial bid)**

**Following information must be stated categorically:-**

COMPLETE NAME ADDRESS EMAIL,  
PHONE & FAX NUMBER OF BIDDER

---

---

NAME, ADDRESS, PHONE, FAX NO &  
EMAIL OF LOCAL AGENT IN PAKISTAN (IF  
ANY

---

---

VALIDITY OF BID:

---

COMPLETION PERIOD:

---

ADDRESS OF BANKER WITH AC  
COUNT NO & SWIFT CODE FOR L/C  
OPENING (WHERE APPLICABLE)

---

---

NTN , GST & PST NUMBER (FOR  
PAKISTAN BASE COMPANY ONLY

---

TOTAL QUOTED COST FOR REGION#1

---

TOTAL QUOTED COST FOR REGION#2

---



**DRAFT CONTRACT**

**CONTRACT NO. PROC-SERVICES/CASE NO. .... /  
NAME OF SERVICES**

THIS **Contract for hiring of (Name of Services) (“Contract”)** is made at Islamabad as of this----- day of -----/year of execution, by and between

**Oil & Gas Development Company Limited** , a body corporate, having its office at OGDCL House, Jinnah Avenue, Sector F-6, Islamabad (hereinafter referred to as the “Company” which expression shall include its successors and assigns) and

**M/s (Name of Contractor or Consultant as the case may be)** having its office at address..... (hereinafter referred to as the “Contractor / Consultant” which expression shall include its successors and assigns)

Contractor/ Consultant and Company may hereinafter be collectively referred to as the “Parties” and each individually as a “Party”.

**WHEREAS**, The Company is desirous of hiring timely, efficient and reliable (Name of Services) .....services under rate running contract for a period of (period)on as and when required basis.

**AND WHEREAS**, the Company invited bids for providing Name of Services ..... through Tender Enquiry No. PROC-FD/Case No..... and the Contractor / Consultant through its Bid Proposal No..... dated ..... warrants and represents for providing efficient and reliable Name of Services .....

**WHEREAS**, the Contractor / Consultant is engaged in the business of rendering the desired services to various E & P companies and it hereby expresses its ability and willingness to provide the desired services along with necessary equipment, type of Contract.

**NOW THEREFORE**, in consideration of the promises and mutual undertaking and covenants hereinafter set forth, the Parties hereby agree as follows:

**SECTION 1. SCOPE OF WORK**

Description of Scope of Work (As described in TOR/Tender enquiry)

**SECTION 2. TERM:**

The initial term of this Contract shall be -----months/years from the date of its acceptance by the contractor till completion of the job whichever is later unless earlier terminated under the provisions hereof. Any extension in the term of Contract will be subject to mutual consent of both the parties.

**SECTION 3. CONTRACT DOCUMENTS:**

The following documents shall be deemed to form and be read and construed as integral part of this Contract:

- (a) This Contract.
- (b) Company’s LOI.
- (c) Company’s Tender documents
- (d) Contractor’s Technical & Financial bid and all correspondence/ clarification made thereafter.

Any inconsistency between the above documents of this Contract shall be resolved by giving precedence in the order in which they are listed above.

#### **SECTION 4. PRICING TERMS:**

- 4.1 The Services under this Contract shall be rendered at an estimated Cost of \_\_\_\_\_ as detailed below:
- 4.2 All prices charged under this Contract shall remain firm during the period of this Contract.
- 4.3 The prices should be quoted in USD. However payment to all Pakistan based companies will be made through cross cheque in 100% Pak Rupees, at actual, against verified invoices at official exchange rate prevalent on the date of payment.
- 4.4 To Foreign based Companies, the payment will be made in US\$, at actual against verified invoices through Irrevocable Letter of Credit (LC).
- 4.5 However, any payment made after thirty (30) days shall not in any way attract any markup, interest, surcharge or charges, etc.
- 4.6 To avoid delay in payment, it is essential that the invoices shall:
  - (a) be duly signed and stamped and type-written in English.
  - (b) be identified by the Contract number.
  - (c) contain sufficient description of services provided by the Contractor.
  - (d) state the location of the Company where Services have been provided.
  - (e) state the period of Services, duly verified with sign and stamp of Head of Department.
  - (f) be precise and strictly in accordance with the Contract.
  - (g) contain any other information deemed essential either by the Contractor or by the Company.
  - (h) Invoices must be submitted to Manager Accounts for onward submission to concerned Manager for verification.

#### **SECTION 5. TAXES AND DUTIES:**

- 5.1 The contract price includes all taxes (except Provincial Sales Tax/ Islamabad Capital Tax on services in Pakistan), duties, fees, levies and any other relevant charges payable/ applicable on the last date of submission of main/supplementary financial bid inside and outside Pakistan, except if OGDCL imports material in its own name it will bear duties/ import taxes/ port charges. The Contractor will be responsible for all the direct taxes (present or future) with respect to income/ payments of total contract amount, under the scope of the contract.
- 5.2 Indirect taxes (Provincial Sales Tax/ Islamabad Capital Territory Sales Tax on services) in Pakistan will be borne by OGDCL at actual where applicable. The contract price will be adjusted for any subsequent changes in the rates of indirect taxes as made applicable thereafter by the relevant authorities in Pakistan.
- 5.3 Any direct taxes, duties, fees, levies and other relevant charges, present or future, assessed or payable inside or outside Pakistan by the Contractor and its sub-contractor and /or by the expatriate personnel deputed by the Contractor and its sub-contractor in connection with its performance under the Contract shall be the sole and exclusive responsibility of the Contractor.
- 5.4 The Contractor shall be responsible and pay all taxes on its income outside and in particular on its income in Pakistan under the Contract and under the laws of Pakistan.
- 5.5 The Company shall have the right, as provided under the laws of Pakistan to meet its obligations and in particular to deduct from the payment due to the

Contractor (against entire contract value including supplies and / or services components etc as applicable) , income tax at source at the rates prevailing from time to time, from the invoiced amounts, or such reduced rates fixed by the taxation authorities in Pakistan for the Contractor on production of current and valid documentary evidence by the Contractor from competent tax authorities in Pakistan and pay such amount to appropriate authorities.

- 5.6 The Contractor shall also be responsible for any income taxes levied on the Contractor's and its sub-contractor's expatriate personnel, under the laws of Pakistan and for all social security issuances and other contributions for the Contractor's expatriate personnel regardless of whether such contributions are levied on employer or employee or both in Pakistan or outside Pakistan.
- 5.7 The Contractor shall keep the Company duly informed about the steps taken by the Contractor in order to meet its obligations under the Contract and provide the necessary documents to the Company in this connection.
- 5.8 The Contractor shall indemnify the Company against any claim which might occur due to non compliance by Contractor of any legal obligation regarding the taxes, duties, fees, levies, or other charges, including taxes on income in Pakistan and any other payments to the relevant Government or Governmental agencies or any other applicable authority.
- 5.9 Understanding reflected under the above tax clause would prevail in case of any understanding to the contrary that may be reflected with respect to tax matters, in any other clause of the contract.

#### **SECTION 6. ADJUSTMENT OF CONTRACT PRICE:**

The Contract value (price) shall be subject to adjustment as a result of addition / reduction in scope of work. However unit price quoted for such work shall be used as base price for computation of final invoice. Contractor should take approval for such changes in writing from the Company. Rates and quantum of any work, not covered in the scope of work shall be subject to approval of Company.

#### **SECTION 7. CONTRACTOR'S OBLIGATIONS:**

- 7.1 The Contractor warrants and represents that all Services along with necessary equipment provided under this Contract shall be in accordance with good industry practice and the Contractor shall use every reasonable means for efficient and timely performance and provision of the Services.
- 7.2 The equipments, tools and materials utilized by the Contractor in performance of this Contract shall be handled and utilized with due care and diligence and proper record of consumables etc shall be maintained and made available to the Company upon request.
- 7.3 The Contractor shall secure and maintain during the performance of this Contract, all licenses, permits, authorization and certification required under the laws of Pakistan and applicable to Contractor. Company has the right to inspect such licenses, permits, authorization and certificates and the Contractor shall forthwith comply with such request.
- 7.4 Contractor shall employ and depute for the execution of Services, persons who are careful, skilled and experienced in their profession. The Company' shall have the right to ask the Contractor to replace any person employed by the Contractor for execution of Services who, in the sole opinion of Company, misbehaves, is incompetent or negligent in the performance of his duties or fails to conform with any particular provisions with regard to safety which may be set out in the Contract, or any conduct which is prejudicial to safety or health,

and such person shall not be employed again for the Services without the permission of the Company.

- 7.5 Contractor and its personnel shall, when using Company's premises, adopt and observe all safety, security, fire and health measures and comply with all reasonable directions relating to health and safety rules and emergency evacuation plans as notified or as directed by the Company.

**SECTION 8. DECLARATION:**

- 8.1 The Contractor hereby declares that it has not obtained or induced the procurement of any Contract, right, interest, privilege or other obligation or benefit from Company through any corrupt business practices.
- 8.2 Without limiting the generality of the foregoing, the Contractor represents and warrants that it has fully declared the brokerage, commission, fees etc. paid or payable to anyone and not given or agreed to give and shall not give or agree to give to anyone within or outside Pakistan either directly or indirectly through any natural or juridical person, including its affiliate, agent, associate, broker, Contractor, director, promoter, shareholder, sponsor or subsidiary, any commission, gratification, bribe, finder's fee or kickback, whether described as consultation fee or otherwise, with the object of obtaining or inducing the procurement of a contract, right, interest, privilege or other obligation or benefit in whatsoever form from the Company, except that which has been expressly declared pursuant hereto.
- 8.3 The Contractor certifies that it has made and shall make full disclosure of all agreements and arrangements with all persons in respect of or related to the transaction with the Company and has not taken any action or will not take any action to circumvent the above declaration, representation or warranty.
- 8.4 The Contractor accepts full responsibility and strict liability for making any false declaration, not making full disclosure, misrepresenting facts or taking any action likely to defeat the purpose of this declaration, representation and warranty. It agrees that any Contract, right, interest, privilege or other obligation or benefit obtained or procured as aforesaid shall, without prejudice to any other rights and remedies available to the Company under any law, Contract or other instrument, be voidable at the option of the Company.
- 8.5 Notwithstanding any rights and remedies exercised by Company in this regard, the Contractor agrees to indemnify Company for any loss or damage incurred by it on account of its corrupt business practices and further pay compensation to Company in an amount equivalent to ten times the sum of any commission, gratification, bribe, finder's fee or kickback paid by the Contractor as aforesaid for the purpose of obtaining or inducing the procurement of any Contract, right, interest, privilege or other obligation or benefit in whatsoever form from Company.

**SECTION 9. PERFORMANCE BOND/SECURITY DEPOSIT:**

The Contractor shall provide to the Company, within fifteen (15) days of the award of the Contract, a Performance Bond in the form of an irrevocable, independent, unconditional, direct obligation of the bank and first and simple demand guarantee of a Pakistani Scheduled Bank or branch of a foreign bank operating in Pakistan, except NIB Bank, in the amount equivalent to 10% (Ten percent) of the total contract value in Pak Rupees/US\$ strictly in accordance with the format given at LOI to cover and secure the Contractor's faithful performance and execution of this Contract. The charges and expenses payable in connection with the issuance, extension, renewal and maintenance of the Performance Bond shall be borne and paid by the Contractor. The Performance Bond shall be valid and shall be maintained in full force effect until - -----/ extendable six (06) months beyond the validity of the Contract. The

Company has sole and absolute right to encash the Performance Bond without any prior notice to the Contractor in the event of any breach, failure, non-compliance or delay in the performance of the Contract.

#### **SECTION 10. LIABILITIES:**

- 10.1 Each party shall defend, indemnify and hold the other party harmless from and against any claim INCLUDING THIRD (3rd) PARTIES arising out of (i) loss or damage to its own property, and / or (ii) death of or injury to its own personnel.
- 10.2 Each party shall be liable for, and shall defend, indemnify and hold the other Party and its members/affiliates, co-ventures (if any), contractors or subcontractors, and it's and their respective employees, directors, officers, agents and invitees harmless from and against. all claims, demands, causes of action, judgments, awards, damages, losses, costs, expenses, expenses and liabilities of any kind and character arising out of third party property damage (including death) caused by the indemnifying Party's negligence during the performance of the Contract.
- 10.3 Notwithstanding any other provision of this Contract, Company shall defend, indemnify and hold harmless the Contractor from and against all liabilities, claims, damages, losses and costs relating to or resulting from (a) through (e) below, including any and all personal injury, death and loss of or damage to the drilling rig, vessel or platform and all other property arising there from (except if caused by Contractor's Gross Negligence or willful misconduct):
- (a) damage to or loss of or impairment to any well (including the casing) or well bore;
  - (b) killing of or the bringing under control of any well;
  - (c) damage to or loss or any reservoir or productive formation, or subsurface minerals or structure or the loss of oil or gas therefore in;
  - (d) blowout, fire, explosion, catering , or any uncontrolled well condition;
  - (e) pollution, as well as containing, controlling and cleaning up any pollution, contamination or debris.

Gross Negligence or Willful Misconduct means any act or failure to act (whether sole, joint or concurrent) by a person that was intended to cause or was in reckless disregard of, or wanton indifference to, the harmful consequences to the safety or property of another person which the person acting or failing to act knew, or should have known, would result from such act of omission, provided that Gross Negligence or Willful Misconduct does not include any act or failure to act insofar as it: (i) constituted mere ordinary omission or oversight; or (ii) was done or omitted in accordance with the express instructions or approval of all parties."

The liability clause will be applicable to both parties i.e. OGDCL and the contractor and therefore its ambit and scope will be interpreted accordingly.

#### **SECTION 11. INDEMNITIES:**

- 11.1 Neither Party shall be liable to the other for any punitive, indirect or consequential damages sustained by the other including without limitation business interruptions, loss of profits, loss of use of assets, loss of data and loss of contracts, and each Party shall hold the other Party harmless in respect thereof.
- 11.2 The Contractor shall indemnify the Company against all motions, proceedings, claims, liens and demands whatsoever which may be made against the Company by the third parties for or in respect of or out of any failure by the Contractor in performance of its obligation or wrongful performance under this Contract or any act or omission in connection therewith. Should Company have

to pay any moneys in respect of any such claims or demands, the amounts to be paid and the costs incurred by the Company connection therewith, shall be charged in to and paid by the Contractor in full.

#### **SECTION 12. LIQUIDATED DAMAGES:**

- 12.1 If the contractor fails to deliver any or all of the goods/services within the time periods(s) specified in the Contract, the purchaser shall, without prejudice to other remedies under the Contract, deduct from the Contract Price/Bank Guarantee as liquidated damages, a sum not more than 0.5% of the contract price per week or part thereof for first four weeks, 1.00% per week for next four weeks and 1.5% per week exceeding four weeks upto maximum extent of 10% of the contract value.
- 12.2 In case the purchaser is satisfied that the delayed/defective services/shipment was due to some mistake or circumstances beyond the control of the contractor and the contractor has not intentionally or negligently contributed in the delay, the purchaser may impose Liquidated Damages for not more than a sum equivalent to 0.5% of the delayed or defective shipment per week or part thereof for first two weeks, 1.00 per week for next three weeks and 1.5% per week exceeding five weeks but not exceeding 10% of the contract value of the delayed/defective shipment provided that the Contractor takes immediate remedial measures for the replacement of defective shipment and takes prompt steps to mitigate the delay. The Purchaser may however, impose Liquidated Damages as per clause 12.1 above if the delayed or defective shipment/ services has affected the project completion schedule or has resulted in Production losses.
- 12.3 Even after imposition of LDs, if the supplier fails to materialize the delivery (material and or services); the Purchaser reserves the right to cancel Purchase Order/Contract/LC and forfeit the Guarantee (if applicable) after intimating the supplier for such cancellation/forfeiture.

#### **SECTION 13. PATENT RIGHTS:**

The Contractor shall protect, indemnify and hold the Company harmless from and against all claims, proceedings, demands, damages, costs, charges and expenses whatsoever for or on account of infringement of any patent rights, design, trade-mark, industrial design or name or other protected rights in respect of any design, method, machine work, material etc. used for or in connection with the Services.

#### **SECTION 14. DIRECTIONS:**

The Contractor and its personnel must, when using Company's premises, adopt and observe all safety, security, fire and health measures and comply with all reasonable directions relating to health and safety rules and emergency evacuation plans as notified or as directed by the Company or its representative.

#### **SECTION 15. CONFIDENTIALITY:**

- 15.1 Any data provided by the Company or which the Contractor or its employees have access to, or which they acquire directly or indirectly under this Contract or during the performance of this Contract, shall be deemed Confidential Information. Duplication or disclosure of such Confidential Information by Contractor or any one claiming through it without the prior written consent of the Company is strictly prohibited. All Confidential Information shall be the sole property of the Company. The Contractor hereby agrees not to disclose said data, information, any interpretations thereof, or data derivative there from or any information relating to Company's facilities, installations and operations etc to unauthorized parties or person. This Section also applies to any sub-

consultant, assignee or consultants used by the Contractor. The obligations under these provisions shall survive the termination or expiry of this Contract.

- 15.2 Neither the Contractor nor any of its employees shall, except with the prior written consent of the Company, take ground or aerial photographs of the site, rig, installation or existing facilities of the Company.
- 15.3 The Contractor further undertakes that it shall not, except with the prior written consent of the Company:
- i) make any reference publicly, whether to the press or in books, brochures, internal publications, publicity material, magazines and periodicals or by advertisement through radio, television or films or by any other medium relating to:
    - a) the Contract or its terms and conditions,
    - b) the nature or extent of Services carried out by the Contractor,
    - c) the method, materials, or equipment used and personnel employed, or
    - d) any other Company information in the possession of the Contractor.
  - ii) disclose or convey any of the matters or information referred to in (i) above to any employees of the Contractor not directly concerned with the Contract.

**SECTION 16. DEFAULT:**

- 16.1 If the Contractor is unable or unwilling to perform its Services in accordance with terms of the Contract, the Company may obtain conforming Services from other sources, in which case, the Contractor shall be liable to the Company for the increased cost, if any, incurred by the Company for procuring such Services from other sources.
- 16.2 The Contractor shall also be in default under the Contract if the Contractor (a) fails to fully and timely perform any of its material obligations under the Contract (b) becomes insolvent or seeks relief under the bankruptcy laws.

**SECTION 17. ARBITRATION:**

- 17.1 If any technical question, difference or dispute arises under this Contract, the Parties shall use their best efforts to promptly resolve such dispute, controversy or disagreement. However, if the dispute continues, either Party may give written notice to the other for appointment of an expert to resolve the dispute. The expert shall be preferably a Pakistani national and shall have at least ten years of experience in the relevant technical field.
- 17.2 If any question, difference or dispute arises regarding the rights, obligations or performance by the Parties under this Contract, the Parties shall use their best efforts to promptly resolve such dispute, controversy or disagreement. This includes without limitation the question of whether one or the other is in default and what action if any shall be taken to remedy such default. If the Parties are unable to resolve such question, difference, dispute and controversy, the matter may be referred to arbitration. Either Party may notify the other in writing specifying the nature of the dispute and designate one arbitrator to whom such dispute shall be referred requesting that the other party give notice in writing within fifteen (15) days after receipt of the notice of designation of the second arbitrator. The two arbitrators shall within fifteen (15) days after the receipt of notice of the second arbitrator, appoint an umpire whose decision with respect to the dispute shall govern in the event that the arbitrators shall fail to agree. In the event that second arbitrator is not designated within the time specified, the first arbitrator shall have full and complete power to determine the dispute.

- 17.3 Arbitration shall be precedent in any action of law and that the provisions of the Arbitration Act, 1940 and rules framed thereunder shall apply. The venue of the arbitration shall be in Islamabad, Pakistan.
- 17.4 The expenses of arbitration shall be charged equally to the Parties unless the award of the arbitrator(s) or the umpire, as the case may be, otherwise provide.

**SECTION 18. TERMINATION:**

- 18.1 In the event of default by the Contractor, the Company shall have the right to terminate the Contract for cause, by giving written notice effective ten (10) days after the date of such notice, unless otherwise specified therein. If the Contractor cures such default within the ten (10) days period, or provides evidence to satisfy the Company that such default does not exist. In addition to any other remedy available under law or in equity, the Company shall be entitled to recover all actual damages, costs and losses incurred by the Company as a result of default by the Contractor.
- 18.2 The Company shall have the right to terminate the Contract, in whole or in part, without any cause at any time upon thirty (30) days' prior written notice. Upon receipt of such notice of termination, the Contractor shall promptly cease all further Services under the Contract with such exceptions, if any, specified in the notice of termination. The Company shall pay the Contractor for all Services performed and obligations incurred prior to the date of termination in accordance with the terms of the Contract.

**SECTION 19. FORCE MAJEURE:**

- 19.1 "Force Majeure" shall mean an unforeseeable event that impairs the ability of the Party affected by it to wholly or partially perform its obligations under this Contract. In the event of either party hereto being rendered unable, wholly or in part, by Force Majeure circumstances to carry out its obligations under this Contract, then such party by giving notice with satisfactory evidence of such Force Majeure circumstance(s) relied upon, the obligations of the party giving such notice so far as they are affected by such Force Majeure shall be suspended for the period during which the party, is rendered unable as aforesaid, but for no longer period. However, such notice must be given within fourteen (14) days of occurrence of Force Majeure event. The terms Force Majeure as employed herein, shall include but not be limited to acts of God or war, war whether declared or undeclared; acts of terrorism or sabotage, or public enemy; riots and insurrection; civil commotion; revolution; embargo, blockade, invasion or act of foreign enemies; epidemic; landslide, lightening, earthquake, loss of well, reservoir failure, change of law or policy; or any other cause beyond the control of the affected Party which materially and adversely affects the performance by such Party of its obligations under or pursuant to this Contract, other than to make payments due hereunder, acts of enemies, civil insurrection, fires, floods, earthquakes or other physical disasters, order or request of Government, blockade or embargo. It is however, clarified that strikes, lockouts, shortage or non availability of raw materials, rains disturbances, other labour disputes or non availability of transport shall not be included in the term "Force Majeure". During the established period of Force Majeure as contained hereinabove, the Contractor shall not be entitled to payment for Services and the Company shall not impose penalty.
- 19.2 In case the Force Majeure contingencies last continuously for more than one month, both parties will agree on the necessary arrangement for the further implementation of the contract. In case further implementation is unforeseeable and impossible, both parties shall arrange for the termination of the Contract,



but without prejudice to their right and obligations prior to such termination it being understood that each party shall fulfill its contractual obligations so far as they have fallen due before the operation of Force Majeure.

**SECTION 20. LICENSE, PERMITS, AUTHORIZATION AND CERTIFICATION:**

The Contractor / Consultant hereby warrants and undertakes that all kinds of licenses, permits, authorizations and certifications required under the laws of Pakistan and applicable to the Contractor / Consultant are intact, valid and possessed by the Contractor / Consultant and shall be maintained during the performance of this Contract. The Company has the right to inspect, or demand for such licenses, permits, authorization and certificates and the Contractor/ Consultant shall forthwith comply with such inspection on demand.

**SECTION 21. PHOTOGRAPHY AND ADVERTISING:**

21.1 The Contractor undertakes that neither the Contractor nor any of its employees shall, except with the prior written consent of the Company shall take, any ground or aerial photographs of the site, rig, installation or existing facilities at or around the work site.

21.2 The Contractor further undertakes that neither the Contractor nor any of the Contractor's personnel shall, except with the prior written consent of the Company:

- i. make any reference publicly, whether to the press or in books, brochures, internal publications, publicity material, magazines and periodicals or by advertisement through radio, television or films or by any other medium relating to:
  - the Contract or its terms and conditions,
  - the type or extent of the works, services, jobs required to be carried out by the Contractor,
  - the method, materials, or equipment used and personnel employed,
  - any information in the possession of the Contractor as to the operations of the Company.
- ii. Disclose or convey any of the matters or information referred to in (a) above to any employees of the Contractor not directly concerned with the Contract.

**SECTION 22. SECURITY:**

22.1 If otherwise mentioned in TOR, Company shall provide appropriate site security including, as from time to time may be necessary, security personnel and security services at the work site or during transportation of personnel and equipment to and from the work site.

22.2 If otherwise mentioned in TOR, it is the express intent of the Parties that any delay in the performance of Services or provision of equipment, or part thereof related directly or indirectly to security issues shall under no circumstances be deemed a breach of Contractor's obligation under the Contract.

**SECTION 23. INSURANCE DEMURRAGE:**

23.1 The Contractor shall within seven (07) days of the date hereof take out and shall maintain until maturity of the Contract, standard insurance policies, which shall include Contractor's waiver of subrogation as follows:

- (a) Worker's compensation insurance covering all employees, engaged directly or indirectly in the performance of the Services in accordance with the applicable statutory requirements of the state or nation having jurisdiction over such employees.
  - (b) All risk insurance cover for the Services and Equipment including without limitation Equipment and machinery and other materials, if any supplied hereunder by the Contractor.
  - (c) The foregoing insurance shall be maintained with insurers that are satisfactory to the Company, and the terms of coverage for the foregoing insurance shall also be satisfactory to the Company and shall be evidenced by certificate to be furnished to Company. Such certificates shall provide that ten (10) days written notice shall be given to Company prior to cancellation of any policy. In the event the Contractor fails to effect or keep in force the insurances then the Company without prejudice to any other rights, shall effect and keep in force such insurance's at the Contractor's cost and risk.
  - (d) It shall be the duty of the Contractor to notify the insurers of any insurance referred to above or of any matter or event, which by the terms of such insurance are required to be so notified.
- 23.2 The Contractor shall indemnify the Company against all suits, proceedings, claims, liens and demands whatsoever which may be made against the Company by the third parties for or in respect of out of any failure by the Contractor in performance of its obligation or wrongful performance under this Contract or any act or omission in connection therewith. Should Company have to pay any moneys in respect of any such claims or demands, the amounts to be paid and the costs incurred by the Company in connection therewith, shall be charged to and paid by the Contractor in full.

#### **SECTION 24. EMPLOYMENT OF PAKISTANI NATIONALS**

The Contractor shall employ qualified Pakistani nationals for its Services, if available. If necessary, Contractor may employ expatriate professionals only after making all out efforts to employ Pakistani nationals. The Contractor shall make reasonable efforts to train Pakistani nationals in order to gradually replace its expatriate staff. Unskilled workers if needed for the Services shall be hired from the area where the Services are being performed.

#### **SECTION 25. ASSIGNMENT:**

The Contractor shall not sub-contractor or assign either whole or part of its obligations under this Contract without the prior written consent of the Company and such consent if given shall not relieve the Contractor from any liability or obligation under this Contract. The Contractor shall be responsible for the acts, defaults and negligence of any sub Contractor, its personnel or agents as fully as it they were the acts, defaults or negligence of the Contractor, or its personnel.

#### **SECTION 26. ENTIRE CONTRACT:**

The documents mentioned in Section-3 of this Contract constitute the entire understanding between the Company and the Contractor on the subject matter and supersede all prior discussions, communications and agreements regarding the subject matter, whether written or oral.

#### **SECTION 27. AMENDMENTS:**

No variation in or modification of the terms of this Contract shall be made except by written amendment signed by the duly authorized representative of the Company and the Contractor.

**SECTION 28. GOVERNING LAW:**

This Contract shall be construed, interpreted and governed by the laws of the Islamic Republic of Pakistan.

**SECTION 29. ERADICATION OF CORRUPTION:**

All vendors, Suppliers, Contractors, Consultants and alike are encouraged to inform the Managing Director and Heads of Departments in case where any Company’s employee asks for any type of favour whether monetary or in kind. You can contact the M.D. and Heads of Departments on the following addresses, phone numbers, faxes or e-mail:

- i MD & CEO  
Oil & Gas Development Company Limited  
OGDCL House, Blue Area, Islamabad.  
Tel No. 051-9209701  
Fax No. 051-9209708  
E-mail: md@ogdcl.com
- ii GM (SCM)  
Tel No. 051-920023540  
Fax No. 051-9209859

**SECTION 30. NOTICES:**

Any notice, request demand, statement, call, question, intimation, reference, or other Communication required for execution of this Contract shall be made in writing and shall be directed by courier service or facsimile to the address of the Parties as follows:

**To the Company:** General Manager (Production)  
Oil & Gas Development Company limited  
OGDCL House, Jinnah Avenue, Sector F-6  
Blue Area, Islamabad, Pakistan  
Telephone: 0092 - 51-92002-3658  
Facsimile: 0092 - 51-

**To the Contractor:** Mr. \_\_\_\_\_.  
M/s \_\_\_\_\_.  
Address:- \_\_\_\_\_  
Telephone: 0092 -  
Facsimile: 0092 -

Notices shall be deemed served when received by the addressee.

**IN WITNESS WHEREOF**, the Parties hereto have executed this Contract as of the date first above written.

<b>COMPANY</b>	<b>CONTRACTOR</b>
Signature_____	Signature_____
Name_____	Name_____
Position_____	Position _____
Witness _____	Witness_____
Witness_____	Witness_____