

This bill of materials is intended to represent one of several possible refractory lining configurations and has not been approved for construction. Any other use to which this bill of material is put is at the sole risk and responsibility of the customer. This bill of material is the property of HARBISON-WALKER Refractories Company and shall be returned upon request. This bill of materials is confidential and is loaned upon the condition that it shall not be reproduced or copied, in whole or in part, nor used for furnishing information to others, nor for any purpose detrimental to the interest of HARBISON-WALKER Refractories Company.

PRESSON DESCON INTERNATIONAL	Date Drawn: 1/20/2009	Revisions	
	Estimated by: WAR	1	JOB No.2009-0257 SPLIT KS-4, ADD ANCHORS AND PAPER. CHANGE QUANTITIES.
PAKISTAN	Checked by: ~		MDP 4/22/2009
Description COUNT FOR ONE (1) SULFUR CONDENSER	Reference ORTLOFF ENGINEERS, LTD REFRACTORY SPECIFICATION FOR REACTOR FURNACE AND WASTE HEAT RECLAIMER PACKAGE INCLUDED IN SALES ENGINEERING JOB FILE NUMBER: 2009-0012	2	JOB No.2009-0327 REMOVE 1-A-1 ANCHORS, AND 51 PCS 1-A-1/12 NOW 63 WITH 56 PCS 1-A-2 1/2 NOW 68.
			MDP 4/23/2009

Units	Net Qty.	Gross Qty.	Overage	Quality	Size or Description	Size/Shape Code	Lining Location	Comments	Cu. Ft. Req'd.	Brick 9" EQ or Total 9" EQ Mortar per unit
	-	1		Drawing Sheets @ \$1500.00/sheet	17" x 22" or 22" x 34"	-	-	-	-	-
1	63	65	3%	304 SS	1-A-1 1/2 METALLIC ANCHOR	118128	BARREL	WELD ON 6" CENTERS	-	-
1	12	15	5%	304 SS	1-A-2 METALLIC ANCHOR	118130	BARREL	WELD ON 6" CENTERS	-	-
1	12	15	5%	304 SS	1-A-2 1/2 METALLIC ANCHOR	118131	BARREL	WELD ON 6" CENTERS	-	-
1	295 lb.	385 lb. ✓	15%	KS-4 GR Plus (0% Rebound Built Into Net Qty)	Gun Mix @ 118 Lb.CU.FT.		BARREL	WORKING VARIES	2.5	-
1	68	70	3%	304 SS	1-A-2 1/2 METALLIC ANCHOR	118131	Nozzle & Endwall	WELD ON 6" CENTERS	-	-
1	448 lb.	550 lb. ✓	15%	KS-4 GR Plus (0% Rebound Built Into Net Qty)	Gun Mix @ 118 Lb.CU.FT.		Nozzle & Endwall	3" WORKING VARIES	3.8	-
1	9 S.F.	10 S.F.	7%	INSWOOL 2300 PAPER	1/8" thick Ceramic Insulation		Nozzle & Endwall		-	-

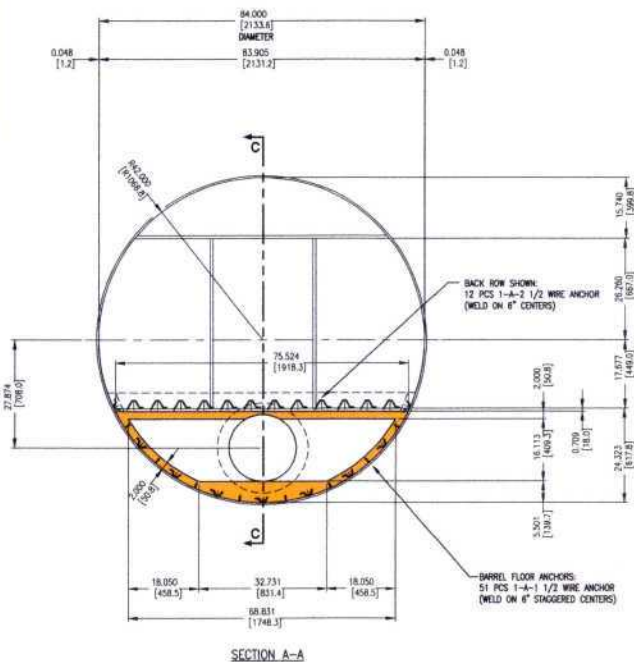

SECTION A-A

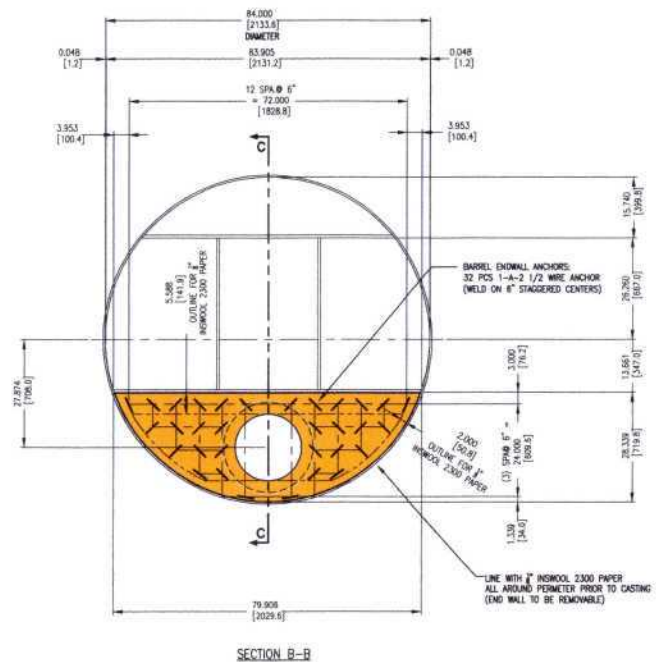

SECTION B-B

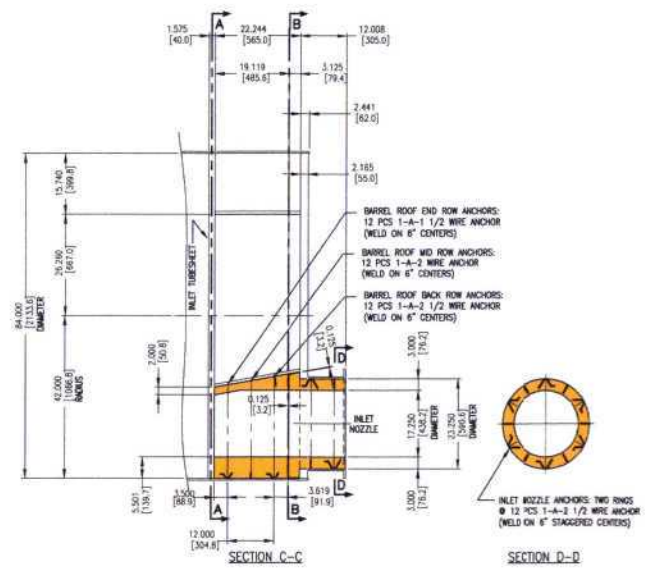

SECTION C-C

SECTION D-D

REFERENCE NOTE: ORTLOFF ENGINEERS, LTD. REFRACTORY SPECIFICATION FOR SULFUR CONDENSER PACKAGE INCLUDED IN SALES ENGINEERING JOB FILE NUMBER: 2009-0012.

LEGEND

KS-4-GR PLUS

2	05/22/09	JOB NUMBER 0001 REFRACTORY ON IT
1	05/22/09	2-REV. 3 OF 10 REV AND CORRECT USE OF 1/2 WIRE ANCHORS.
1	05/22/09	2-REV. 2 OF 10 REV AND CORRECT USE OF 1/2 WIRE ANCHORS.
1	05/22/09	2-REV. 1 OF 10 REV AND CORRECT USE OF 1/2 WIRE ANCHORS.

FOR BILL OF MATERIALS SEE DRAWING NUMBER: P0005440

HARBISON-WALKER REFRACTORIES CO. Cherrington Corporate Center 400 Fairway Drive Moon Township, PA 15108		PRESSION DESIGN INTERNATIONAL (PA) LIMITED Sulfur Condenser (E-1902)
USE COMMERCIAL TOLERANCE, SPEC. CODE "D0" UNLESS OTHERWISE SPECIFIED ON DWG. OR ORDER		P0005440-2

P0005440-2