



OIL & GAS DEVELOPMENT COMPANY LIMITED

KUNNAR/KPD-TAY LPG PLANT & OIL FIELD

C/O TCS Office Tandojam, Distt. Hyderabad, Sindh, Pakistan
 Tel: 022-2761401 (Field Manager), 022-2720747 (I/C Telemetry)
 Fax: 022-2761405

Tender Enquiry No.: TE/KNR/TELE/PE&FD/01/21

Dated: 17-03-2021

SCHEDULE OF REQUIREMENT

Spare Parts for FMC Junior Orifice Assemblies				
S#	Item Description	Part No.	Required Quantities	Material
For 16" Junior Orifice Assembly				
1	Carrier	23-5-118910	01	ASTM A516 Gr70
2	Captive SCREW	11-3-3141190	02	ASTM A193 Gr B7
3	CARRIER (CONNECTOR)	23-5-900011	01	ASTM A516 Gr70
4	PIN (CARRIER CONNECTOR)	13-2-110291	01	316L ST. STEEL
5	LOCATING PIN	12-027005	02	316L ST. STEEL
6	GRUBSCREW 1/4"UNC x 3/8" LG	11-3-525292	01	ST.STEEL
7	O' RING (COVERPLATE)	12-6-450090	01	VITON 90
8	HEX HD SCREW 7/18"UNC x 1-1/4" LG	11-3-144101	02	ASTM A193 Gr B7
9	"O"RING (INTEGRAL ORIFICE PLATE)	12-088230	02	VITON 70
10	INTEGRAL ORIFICE PLATE with Certificate (DATA SHEET ATTACHED) Tag No. FE-4200	C-TR-3408	01	316 ST.STEEL
For 8" Junior Orifice Assembly				
11	Carrier	23-5-108910	01	ASTM A516 Gr70
12	Drive Screw	11-3-004291	02	ST.STEEL
13	Locating Pin	11-3-405293	02	316L ST.STEEL
14	O' RING (COVERPLATE)	12-6-295090	01	VITON 90
15	O'RING (INTEGRAL ORIFICE PLATE)	12-088131	02	VITON 70
16	INTEGRAL ORIFICE PLATE with Certificate (DATA SHEET ATTACHED) Tag No. FE-5200	C-TR-3409	01	316 ST. STEEL

K-Separator
These
Values
entered
NB
02/04/17

Z.O 14.311811
O.P 8.352913386
 $\beta = 0.5836377651$

FMC Ltd

Flow Metering Company Ltd
6 Baird Way, Thetford, Norfolk IP24 1JA
Phone: +44 (0) 1752-522900 Fax: +44 (0) 1752-765101

Orifice Plate Data Sheet

CUSTOMER : STI Servizi Tecnici Industriali
ORDER NUMBER : PO1391-28 Rev 00
FMC REFERENCE No : 91301380
PLATE TAG No : FE-4200
DRAWING No : C-TR-3408
ITEM : 16" 600# Integral Orifice

TEMPERATURE: 19 Deg C
BORE SIZE : 212.122
HEAT No : 284181

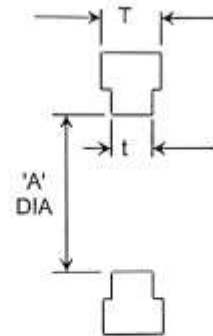
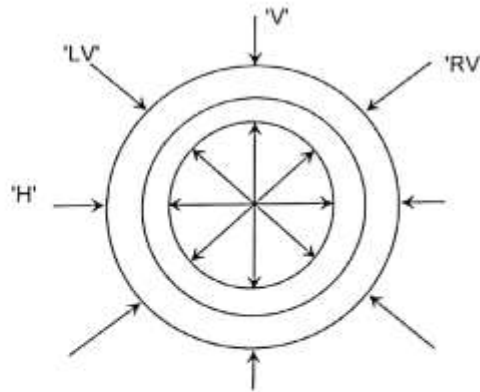

BORE DIAMETER				
'A' ACTUAL ORIFICE BORE				
'H'	'LV'	'V'	'RV'	AVERAGE
212.165	212.161	212.163	212.168	212.164

FLATNESS				
FLATNESS CHECK AT POINTS				
'H'	'LV'	'V'	'RV'	COMMENTS
0.02	0.02	0.02	0.02	Conforming

CORNER RADIUS				
CORNER RADIUS CHECK AT POINTS				
'H'	'LV'	'V'	'RV'	COMMENTS
44.0	44.0	43.0	43.0	Conforming

Inspector :

A circular stamp containing the text 'FMC LTD' and a handwritten signature.

Date : 10/02/2014

FMC Ltd

Flow Metering Company Ltd
6 Delft Way, Delford, Norfolk IP24 1JA
Phone: +44 (0) 1542 822900 - Fax: +44 (0) 1542 765402

Orifice Plate Data Sheet

CUSTOMER : STI Servizi Tecnici Industriali
ORDER NUMBER : PO1391-28 Rev 00
FMC REFERENCE No : 91301380
PLATE TAG No : FE-5200
DRAWING No : C-TR-3409
ITEM : 8" 600# Integral Orifice

TEMPERATURE: 19 Deg C
BORE SIZE : 120.069 '
HEAT No : 284181 '

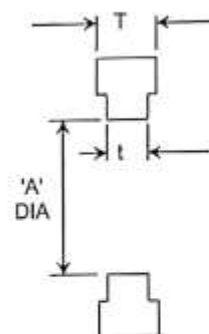
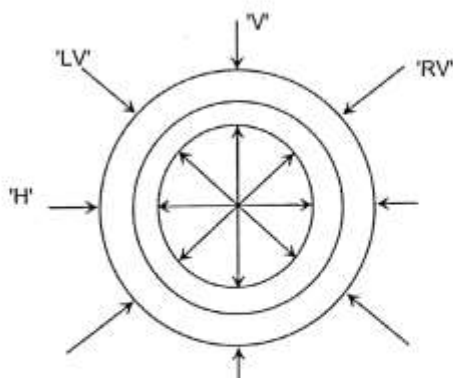

BORE DIAMETER				
'A' ACTUAL ORIFICE BORE				
'H'	'LV'	'V'	'RV'	AVERAGE
120.070	120.090	120.080	120.080	120.080

FLATNESS				
FLATNESS CHECK AT POINTS				
'H'	'LV'	'V'	'RV'	COMMENTS
0.02	0.02	0.02	0.02	Conforming

CORNER RADIUS				
CORNER RADIUS CHECK AT POINTS				
'H'	'LV'	'V'	'RV'	COMMENTS
44.0	44.0	43.0	43.0	Conforming

Inspector :



Date : 10/02/2014

Calculation

Data sheet for FLOW ELEMENT REPCO		NO	BY	DATE	SHEET: 1 OF 1 SPEC#: REV. 3 JOB #: T-130557 P.O. : DATE : 27/11/2013 CHK: JE BY : MC APR:
		0	T.O	09/07/2013	
		1	MC	20/00/2013	
		2	MC	04/10/2013	
		3	MC	27/11/2013	
Tag. No. : FE-5200		Eq. Line No. :			
Service : GAS OUTLET FROM SEPARATOR.		Flow sheet :			
Manuf. : FMC Ltd.		Model No. :			
ELEMENT DATA		Element Type : Orifice Plate-Standard			
		Press. Tap Loc. / Type : Upstream / Flange			
		Element Material : 316 SS			
		Beta Ratio(d/D) : 0.020			
		Element Bore : 120.0894 mm			
		Thickness : 6.0000 mm			
SIZING CRITERIA		Sizing Mode : Exact Bore			
		Reference : AGA 3-1980			
PIPING DATA		Flange : 600# / RF			
		Pipe Size & SCH : 8 In 80 mm			
		Pipe I.D. : 193.8750 mm			
		Flange Material : ASTM A106			
		Pipe Material : Carbon Steel			
COEFFICIENTS		Discharge Coeff.(C) : 0.604		User Factor (Fuser) : 1.000	
		Gas Expan. Coeff.(Y1) : 0.998		Murdock Wet Gas Factor (Fw) :	
		Reynolds No.(Pipe) : 9658144.01		Velocity of Approach Factor (Ev) : 1.083	
		Reynolds No.(Bore) : 15678631.16		Reynolds No.(Pipe - Normal) :	
PROCESS DATA		Base	Maximum Flow	Normal Flow	Property Method
Flow Rate :			70.000		SMMCFD
Diff. Pressure :			500.000		millibar
Pressure Loss :			299.130		millibar
Static Pressure :			1045.000		psig
Base Pressure : 1.013					Bar
Temperature : 70.00			95.00		DEG F
Density : 0.057			4.981		lb/ft3
Spec. Gravity :					User Input
Z-Compressibility Factor : 1.000			1.000		
Viscosity :			0.0142		cP
k-Factor (Cp/Cv) :			1.3780		User Input
Fluid Name / Fluid State : Gas					Gas
Liquid Density :					
Gas Quality :					
Atmospheric Pressure : 14.698					psi
UNCERTAINTY DATA		Uncertainty in Flow Rate : ±0.59%			
		In Discharge Coeff. : ±0.45%			
		In Expansion Factor : ±0.03%			
		In Primary Diameter : ±0.05%			
		In Pipe Diameter : ±0.30%			
		In Density : ±0.30%			
		In Pressure : ±0.26%			
Notes :					

APPROVED
FOR CONSTRUCTION

PRINTED:27/11/2013 11:03:09

This report created by Flowel 4.1.1

As/R/0-13



TENDER DOCUMENTS

TENDER ENQUIRY NO: TE/KNR/TELE/PE&FD/01/21

Procurement of Spare Parts
for
FMC Junior Orifice Assemblies

FIELD MANAGER KNR/KPD-TAY
(LOCAL PROCUREMENT)
OIL & GAS DEVELOPMENT COMPANY LIMITED

ISSUING DATE: March 22, 2021

BID SUBMISSION DATE: April 22, 2021

OGDCL SALES TAX REGISTRATION

NO. 07-02-2802-001-55

INVITATION FOR BIDS

BIDDING DOCUMENT

TENDER NO. TE/KNR/TELE/PE&FD/01/21

TABLE OF CONTENTS

CLAUSE NO.	SUBJECT	PAGE NO.
1.	INSTRUCTIONS TO BIDDERS	1
2.	BID PRICES	2
3.	EARNEST MONEY	2
4.	SEALING AND MARKING OF BIDS	3
5.	DEADLINE FOR SUBMISSION OF BIDS	4
6.	LATE BIDS	4
7.	BID OPENING	4
8.	DETERMINATION OF RESPONSIVENESS	5
9.	ISSUANCE OF LOCAL PURCHASE ORDER (LPO)	5
10.	PERFORMANCE BOND	5
11.	PAYMENT	6
12.	DELIVERY SCHEDULE	6
13.	EXTENSION IN THE DELIVERY PERIOD	6
14.	PENALTY	7
15.	FORCE MAJEURE	7
16.	INSPECTION AND TEST	8
17.	WARRANTY	8
18.	QUALIFICATION OF SELECTED BIDDERS	8
19.	LITIGATION CLAUSE	9

ANNEXURE:

A	SCHEDULE OF REQUIREMENT
A-1	GENERAL TERMS & CONDITIONS
B	BIDDING FORM & BID SUMMARY SHEET (TECHNICAL BID)
B-1	BIDDING FORM & BID SUMMARY SHEET (FINANCIAL BID)
C	BANK GUARANTEE AS EARNEST MONEY (FORMAT)
D	DECLARATION OF FEES, COMMISSION & BROKERAGE ETC(CERTIFICATE)

- E LOCAL PURCHASE ORDER (FORMAT)**
- F BANK GUARANTEE AS PERFORMANCE BOND (FORMAT)**
- G BANK GUARANTEE FOR ADVANCE PAYMENT (FORMAT)**

OIL & GAS DEVELOPMENT COMPANY LIMITED

KNR/ KPD-TAY LPG Plant & Oil Field

NO: - TE/KNR/TELE/PE&FD/01/21

Dated: 17-03-2021

SUBJECT: Procurement of Spare Parts for FMC Junior Orifice Assemblies

NOTE: BIDDERS SHOULD ALSO REFER TO THE “MASTER SET OF TENDER DOCUMENTS” AVAILABLE AT OGDCL’S WEBSITE AT THE FOLLOWING ADDRESS:

<http://www.ogdcl.com/UploadFolder/tender/MasterSetofPressTenderDocumentsLocal.pdf>

Oil & Gas Development Company Limited (hereinafter referred to as the Purchaser) invites sealed bids from eligible Bidders for supply and delivery of goods, materials, equipment and/or services described in the schedule of requirement as Annexure “A” hereof.

The bid will be opened on the date mentioned in SOR / Tender Notice.

1. **INSTRUCTIONS TO BIDDERS:-**

- 1.1 Only the Bids of bonafied buyers of Tender Document will be entertained. The Bidder shall bear all cost associated with the preparation and delivery of its Bid, and the Purchaser will in no case be responsible or liable for those costs.
- 1.2 In case of any doubt as to the meaning of any portion of the Specifications or other Terms and Conditions, Bidder may seek clarification of the same in writing, but not later than two weeks prior to deadline for submission of bid prescribed by the Purchaser.
- 1.3 At any time prior to the deadline for submission of Bids, a modification in bidding document in the form of an addendum may be issued in response to a clarification requested by a respective Bidder or even whenever the Purchaser considers it beneficial to issue such a clarification and/or amendment to all Bidders. Any clarification/amendment issued (in general) shall be addressed to all the prospective Bidder(s) who have purchased the Tender Document.
- 1.4 Bidders are required to submit their Bid, which will bear words “CONFIDENTIAL” and Tender # **TE/KNR/TELE/PE&FD/01/21**, **“Procurement of Spare Parts for FMC Junior Orifice Assemblies”**.
- 1.5 The Purchaser does not take any responsibility for collecting the Bids from any Agency.
- 1.6 The Purchaser reserves the right to increase or decrease the quantities or may cancel any or all items shown in the Schedule of Requirement, without assigning any reason thereof.
- 1.7 The Purchaser Reserve the right to have the items inspected by its own representative, or by 3rd party at its own cost (if required).

- 1.8 It must be indicated in the offer that the quotation fully conforms to Technical Specifications and Terms and Conditions of the Tender.
- 1.9 The Purchaser reserves the right to accept or reject any Bid and to annul the bidding process and reject all the Bids at any time prior to award of Purchase Order without assigning any reason and without thereby incurring any liability to the affected bidder(s) or any obligation there under.
- 1.10 Unsolicited advice/clarifications and personal approaches by the Bidder at any stage of evaluation are strictly prohibited and shall lead to disqualification.
- 1.11 In the event that the Bidder submits an alternative Bid(s) whether in whole or against any of the items, a group or sub-group in addition to its Main Bid, the Bids must be marked as “Main Bid” and “Alternative Bid”. Alternative bid(s) which do not conform to the specifications, but meet the performance prescribed in, or the objectives of, the specifications may be submitted. However, only the Alternative Bid of the Bidder whose Main Bid is the lowest evaluated bid will be considered.
- 1.12 A Bidder, who wishes to have its Alternative Bid(s) considered on an equal basis with all other (Main) Bids, must submit a Bid Bond for each Alternative Bids, an Alternative Bid must be submitted in a sealed envelope clearly marked “Alternative Bid”, separate from the Main Bid.
- 1.13 The Bidder is expected to examine all instructions, forms, terms and specifications in the Bidding Documents. Failure to furnish all information required by the Bidding Documents or submission of a Bid not substantially responsive to Bidding Documents in every respect will result in the rejection of the Bid.
- 1.14 All prospective bidders are advised to read carefully all terms & conditions enunciated in the Tender Documents prior to filling / submission of their quotation.

2. **BID PRICES:**

- 2.1. Firm Bid Prices must be quoted as per format of schedule of requirement (SOR).
- 2.2. Bidding form Annexure-B & B-1 must also be duly filled-in, stamped and signed by authorized representative of Bidder.
- 2.3. Prices must be quoted in Pakistani currency inclusive of all taxes and duties, indicating unit price and total Bid prices. GST must be quoted separately along with copy of GST Certificate. Bids offering prices in foreign currency will be rejected. Conditional bid / bid having any prices adjustment formula will also be rejected.
- 2.4. Prices must be quoted including all charges like handling, loading, transportation and un-loading, Octroi and Zila Tax etc. for delivery of material at Purchaser’s stores located at **KNR/KPD-TAY LPG Plant & Oil Field, C/O TCS Office Tandojam, District Hyderabad, Sindh, Pakistan.**
- 2.5. Quoted price shall be valid for 45 days from the opening date of the Financial Bid.
- 2.6. Technical brochure/literature confirming Size, Brand & Country of Origin of quoted items/material must be attached with the Technical Bid (where deemed necessary).
- 2.7. Any quotation not confirming to Clause 2.1 to 2.6 shall be rejected without any right of appeal.

3. SEALING AND MARKING OF BIDS:

- 3.1. The Bidder shall furnish single sealed envelope.
- 3.2. The bid shall be submitted in a sealed envelope marked as under:-

**Field Manager,
KNR/KPD-TAY LPG Plant & Oil Field
C/O TCS Office Tando Jam, District Hyderabad-Sindh, Pakistan
Phone No. 022-2761401, 022-2720747 Fax No. 022-2761405
Email: kunnar@ogdcl.com, telemetry_kunnar@ogdcl.com**

- 3.3. The envelope shall also bear the word “ CONFIDENTIAL” and following identifications:-

Tender Enquiry No. TE/KNR/TELE/PE&FD/01/21

“Procurement of Spare Parts for FMC Junior Orifice Assemblies”

DON'T OPEN BEFORE 10:30 HRS (ON OPENING DATE)

TECHNICAL/FINANCIAL BID(S) (INDICATE ONE ON EACH ENVELOPE)

- 3.4. If the envelope is not marked, as instructed above, the Purchaser will assume no responsibility for the misplacement or premature opening of Bid.

4. DEADLINE FOR SUBMISSION OF BIDS:

- 4.1. All Bids must be delivered/ dropped in the Office of Field Manager, KUNNAR/KPD-TAY LPG Plant & Oil Field (C/O TCS Office, Tando Jam District Hyderabad-Sindh) on or before the prescribed deadline of **1000 hrs on above mentioned date.**

5. LATE BIDS:

- 5.1. Any bid received by the Purchaser after the prescribed deadline for submission of bids will be rejected and returned un-opened to the bidder.

6. BID OPENING:

- 7.1. OGDCL will open the Technical/Financial Bid(s), in the presence of bidder's representative(s) who may chose to attend on date , time & location mentioned above.
- 7.2. The bidder's names, bid prices (with or without discount) including bid price modification and bid withdrawals, if any, and the submission of requisite Earnest Money will be announced at the time of Financial bid opening.

7.3 OGDCL will examine the bids to determine whether they are complete, no computational errors have been made, the required sureties have been furnished, documents have been properly signed, and the bids are generally in order.

7.4 Arithmetical errors found will be corrected as follows:

7.4.1 Where there is a discrepancy between amount in figures and word, the amount in word will prevail.

7.4.2. Where there is a discrepancy between the unit price and the total amount derive from the multiplication of the unit price and the quantity, the unit price as quoted will govern, unless there is an obvious gross arithmetical error in unit price, in which event, the extended amount quoted would prevail.

7.4.3. In case the due date of bids opening falls on a holiday, the bids shall be opened on the next working day.

7. DETERMINATION OF RESPONSIVENESS:

7.1. After opening of the bids, the purchaser will determine whether each bid is substantially responsive to the requirements of the bidding documents.

7.2. For the purpose of this clause, a substantially responsive bid is one, which conforms to all the terms and conditions of the bidding documents without material deviation. A material deviation is one which means in-consistent with the bidding document, affects in any substantial way the scope, quality or prescribed delivery schedule or which limits in any substantial way, the purchaser's right or the bidder's obligation under the contract.

7.3. A bid determined to be a non-responsive will be rejected by the purchaser and shall not subsequently be made responsive by the bidder by correction of the non-conformity.

7.4. The purchaser may waive any minor deviation non-conformity or irregularity in a bid, which does not constitute a material deviation, provided that the waiver does not prejudice or affect the relative standing order of other bidder(s).

7.5. To assist in determining a bid's responsiveness the bidder may be asked for a clarification of his bid. The bidder is not permitted, however, to change bid price or substance of his bid.

8. ISSUANCE OF LOCAL PURCHASE ORDER (LPO):

8.1. The purchaser will issue the local purchase order to the successful bidder whose bid is determined to be technically responsive and financially lowest evaluated.

8.2. Terms & Conditions (General) of LPO are available at Annexure-E.

9. PERFORMANCE BOND:

- 9.1. The successful bidder will have to submit a performance bond in the shape of bank guarantee equal to 10% of total value of order exclusive of GST, from any schedule bank in Pakistan as per format attached at Annexure-F within 15 days of the receipt of Purchase Order.
- 9.2. In case the successful bidder fails to furnish performance bond as per clause 10.1, the firm shall be debarred from participation in any future tender of the purchaser in addition to the action taken against such bidder as per clause 3.5(b).
- 9.3. The purchaser reserves the right to check the authenticity of performance bond from the concerned Bank.

10. PAYMENT:

- 10.1. Progressive Payments will be made as per following payment milestones on the completion of works:
 - 10.1.1. 100% after delivery of material & punch list clearance and provisional acceptance by OGDCL/ Engineering Consultant

11. DELIVERY SCHEDULE:

11.1 Procurement of Spare Parts for FMC Junior Orifice Assemblies

Against this tender is to be completed **WITHIN 04 Weeks** from the date of receipt of firm Purchase/ work order.

12. EXTENSION IN THE DELIVERY / COMPLETION PERIOD:

- 12.1. Providing of the services shall be made by the supplier in accordance with the given delivery schedule in purchase order.
- 12.2. The supplier may claim extension of the time limits as set forth in the purchase order in case of:-
 - 12.2.1. Changes in Scope of Work or in the specifications of goods, material & equipment by the OGDCL.
 - 12.2.2. Delay in provision of clarifications regarding material, drawings and services by the OGDCL
 - 12.2.3. Force Majeure pursuant to clause 15.
- 12.3. Justified reasons subject to a written request high-lighting the same within a period of seven working days prior to expiry of delivery period mentioned in Purchase Order.

- 12.4. It should be noted that a request for extension in delivery/ completion period shall be considered only if the supplier/ contactor agrees in writing to pay any increase in taxes or any other charges levied by the government during the extended delivery period. OGDCL shall not bear any additional price increase during the extended period.
- 12.5. In case of extension in delivery period, the supplier/ contactor will extend validity of Performance Bond accordingly at his cost.
- 12.6. If the supplier/ contactor fails to supply/ complete the ordered services for any reason, within stipulated time, his Performance Bond with the purchaser shall be forfeited and material shall be purchased from elsewhere at his risk and cost.

13. **PENALTY.**

- 13.1. For failure to comply with delivery schedule of purchase order, penalty will be imposed on defaulting supplier as under:-
 - 13.1.1. @ 1 % of the cost of entire order (excluding GST) or of such items as remains unsupplied for every day up to maximum of 10% for 10 days exceeding the delivery period.
 - 13.1.2. If the material is not supplied even after paying penalty for 10 (ten) consecutive days. OGDCL reserves the right to cancel supply order and to obtain the required items from elsewhere at your risk and cost.
 - 13.1.3. In case suppliers fails to deliver the goods against order, the purchaser reserves the right to claim interest/financial charges from the supplier on the amount of advance paid to him as per terms/conditions of order for such a period the supplier has detained the amount of advance.

14. **FORCE MAJEURE:**

- 14.1. The supplier shall not be liable for penalty for delay in delivery of ordered goods, if, and to the extent delay in delivery or other failure to perform his obligation under the purchase order, of being the result of occurrence of Force Majeure i.e. causes such as natural calamities, war, civil disturbance, military action, fire as well as other circumstance proved to the satisfaction of the purchaser to be beyond the reasonable control of the supplier, which may impede the fulfillment of the obligations under the purchase order.
- 14.2. The supplier shall notify the purchaser promptly of the occurrence of Force Majeure and submit his case in writing within 07 days of such occurrence.
- 14.3. If any of the party is prevented to fulfill its assumed obligations by Force Majeure of constant duration of at least one month, the party shall meet for negotiation. If no satisfactory agreement is reached within a period of two months from the commencement of the Force Majeure conditions, either party shall have the right to cancel the purchase order with immediate effect.

15. INSPECTION AND TEST:

- 15.1. The OGDCL's representative(s) shall have the right to inspect and/or test the goods to confirm their conformity with respect to specifications mentioned in the Purchase Order. The representative of Field Manager, Kunnar/KPD-TAY LPG Plant & Oil Field Tando Jam will witness the inspection (where so required).
- 15.2. Should any inspected or tested goods fail to conform to the specifications the purchaser shall reject them and supplier shall replace the rejected goods. All costs incurred on such replacement shall be entirely born by the supplier.
- 15.3. Rejected material/ work shall be moved/ replaced by the supplier within 07 days from the receipt of letter/fax issued by the Field Manager, Kunnar/KPD-TAY LPG Plant & Oil Field, Tando Jam. The supplier shall be liable for the storage charges @ ½% (half percent) of the cost of rejected material on every day basis, if the same is not removed within seven days.
- 15.4. Acceptance/rejection of the material by 3rd party will be final and binding on both the parties.

16. WARRANTY:

- 16.1. The supplier/ contactor shall warrant that all supplied material/ Services under purchase order shall be according to specifications given in Purchase Order and approved drawings/design etc. Any deviation in material, drawing/design (where applicable) will be replaced by the Supplier/ Contactor at his cost.
- 16.2. OGDCL shall promptly notify the supplier in writing, of any claims arising under this warranty.
- 16.3. The supplier/ contactor will invariably provide warranty/guarantees

17. QUALIFICATION OF SELECTED BIDDERS:

- 17.1. OGDCL will determine to its satisfaction whether the bidder selected as having submitted the lowest evaluated, technically responsive bid qualifies to satisfactorily perform the order.
- 17.2. The determination will take into account the bidders financial, technical & production capabilities, availability of items ordered for. The bidder shall provide necessary documents as proof along with the bid.
- 17.3. Any affirmative determination will be a pre-requisite for award of the purchase order to the bidder. A negative determination will result in rejection of the bid.

17.4. OGDCL reserves the right at the time of award of order to increase or decrease to a reasonable extent in the quantity of goods specified in the Tender Document without any change in price or other terms and conditions.

18. LITIGATION CLAUSE:

18.1. without prejudice to other right of the Company, tenderers, their subcontractors and other suppliers shall be disqualified from participating in the bidding process if:

18.1.1. they are or have been at any time during the past five year, involve in litigation, arbitration or any other dispute or even that may in the opinion of the company, have material adverse effect on the Tender's ability to perform the Contract.

18.1.2. Its involvement in litigation is chronic.

18.1.3. Its past conduct or execution of works under contract has been poor.

19. You are encouraged to inform Managing Director & Head of Department on the following addresses/contacts, in case where any OGDCL employee ask for any type of favor whether monetary or in kind:-

DESIGNATION	ADDRESS	TEL #	FAX #	E. MAIL
Managing Director	OGDCL House	051-9209701	051-9209708	
Field Manager	Kunnar/ KPD-TAY	022-2761401	022-2761405	kunnar@ogdcl.com

Yours faithfully,
for (Oil and Gas Development Company Limited)

Field Manager
KNR/KPD-TAY LPG Plant & Oil Field
Oil & Gas Development Company Limited
C/O TCS Office Tando Jam, Distt. Hyderabad, Sindh
Phone No. 022-2761401, 022-2720747
Fax No. 022-2761405
Email:kunnar@ogdcl.com; telemetry_kunnar@ogdcl.com

GENERAL TERMS AND CONDITIONS:

- A. BIDS MUST BE SUBMITTED UNDER TWO ENVELOPES BIDDING SYSTEM i.e. TECHNICAL & FINANCIAL BID SEPARATELY ON/BEFORE DUE DATE.
- B. FINANCIAL BIDS OF ONLY TECHNICALLY RESPONSIVE BIDDERS WILL BE OPENED PUBLICLY.
- C. AFTER TENDER OPENING "TECHNICAL BIDS" WILL BE REVIEWED. THE BIDS WILL BE BROUGHT TECHNICALLY AT PAR BY SEEKING CLARIFICATIONS. THE BIDDERS WILL **NOT** BE ASKED FOR ANY PRICE CHANGE IN THEIR FINANCIAL BIDS DUE TO CERTAIN CLARIFICATIONS AND SUBSEQUENT CHANGE IN THEIR TECHNICAL PROPOSALS. THE BIDDERS WILL **NOT** BE ALLOWED TO SUBMIT SUPPLEMENTARY PRICE PROPOSALS IN A SEPARATE SEALED ENVELOPE TO MAKE IT A PART OF THE ALREADY SUBMITTED UNOPENED FINANCIAL BIDS AND TO ADJUST THEIR QUOTED PRICE SUBSEQUENTLY AFFECTED DUE TO CHANGE IN TECHNICAL PROPOSALS.
- D. SEALED FINANCIAL BIDS OF TECHNICALLY NON-RESPONSIVE BIDDERS WILL BE RETURNED UN-OPENED.
- E. OGDCL RESERVES THE RIGHT TO REJECT ANY OR ALL THE BIDS WITHOUT ASSIGNING ANY REASON.
- F. QUOTED PRICES MUST BE FIRM IN PAK RUPEES ON FOR KUNNAR FIELD BASIS (INCLUSIVE OF GST, OTHER TAXES, AND DUTIES).
- G. OGDCL RESERVES THE RIGHT TO EVALUATE THE BID(S) EITHER ITEM-WISED OR FULL PASKAGE BASIS WITHOUT ASSIGNING ANY REASON. TO QOUTE COMPETITIVE PRICES FOR ALL OR ANY ITEMS ENABLE COMPANY TO DECIDE PURCHASE.
- H. THE VARIATION IN QUANTITY WILL NOT CHANGE THE UNIT COST OF MATERIAL.
- I. NO ADVANCE PAYMENT WILL BE MADE AT THE TIME OF PO.
- J. THE INSPECTION OF MATERIAL WILL BE CARRIED OUT AT SITE IN CASE OF REJECTION, ALL OF THE TRANSPORTATION CHARGES WILL BE AT SUPPLER END.
- K. THE BIDDERS ARE NOT ALLOWED TO QUOTE THE ALTERNATE /EQUIVALENT PRODUCT.
- L. PAYMENTS WILL BE MADE THROUGH X-CHEQUE AS PER COMPANY RULES AFTER RECEIPT AND INSPECTION OF MATERIAL AT SITE.
- M. INCOME TAX/W. HOLDING TAX DEDUCTIONS WILL BE APPLICABLE AS PER COMPANY/GOVT. RULES.
- N. DELIVERY TIME SHOULD BE WITH IN **FOUR Weeks.**
- O. THE BIDDER SHALL ALSO SUBMIT **BID BOND amounting to Rs. 60,000/-** WITH THE BID IN THE FAVOUR OF "OIL & GAS DEVELOPMENT COMPANY LIMITED".