



OIL & GAS DEVELOPMENT COMPANY LIMITED
UCH GAS FIELD, DERA BUGTI-BALUCHISTAN

Annexure-A

Schedule of Requirement

Tender Enquiry No. PROC-WT/UCH-I&II/ATA-2023/MECH-12/2023

“SUPPLY OF HEAT EXCHANGER’S GASKETS FOR UCH-I & UCH-II PLANT ATA 2023”

Sr.	Item description	UOM	Req. Qty.
<u>HEAT EXCHANGER'S GASKETS OF UCH-I :-</u>			
1	<u>Front/Rear Channel Gasket:</u> Material: Soft Steel double jacketed with flexible graphite filler, Size: 1680mm O.D. x 1654mm ID. x 03mm thk (For Amine Reboiler as per Dwg# 658313 – Rev01)	Nos.	04
2	<u>Front /Rear Channel Gasket:</u> Material: Soft Steel double jacketed with flexible graphite filler, Size: 49.8125" O.D x 48.75"ID. x 0.125" thk (For Amine Solution Cooler as per dwg# 658315)	Nos.	06
3	<u>Shell Gasket only:</u> Material: S.S. Double Jacketed with Non- Asbestos Filler, Size: 13.5"O.D.x 12.6875"ID.x 0.125"thk (For Glycol Reboiler as per dwg# 2074A-0)	Nos.	06
<u>HEAT EXCHANGER'S GASKETS OF UCH-II :-</u>			
4	<u>Front / Rear Channel Gasket:</u> Size: 1869 mm O.D. x 1843 mm I.D. x 3.2 mm thk X rib width 12 mm. Type: Soft Steel double jacketed (Lean Amine Trim Cooler)	Nos.	01
5	<u>Front / Rear Channel Gasket:</u> Size: 1647 mm O.D. x 1621 mm I.D. x 3.2 mm thk Type: Soft Steel double jacketed. (For Regenerator Condenser)	Nos.	04
6	<u>Shell and Tube Side Gasket:</u> 1420 mm O.D. x 1380 mm I.D. x 3.2 mm thk x rib width 10 mm, Type: Soft Steel double jacketed (For Regenerator Reboiler)	Nos.	04
7	<u>Front / Rear Channel Gasket:</u> Size: 859 mm O.D. x 833 mm I.D. x 3.2 mm thk Soft Steel double jacketed. (For Treated Gas Cooler)	Nos.	10
8	<u>Tube Side Gasket (Main bundle):</u> Size: 685.8 mm O.D. x 628.25 mm I.D. x 5 mm thk with rib Soft Steel double jacketed (For Glycol Reboiler dehy)	Nos.	02



OIL & GAS DEVELOPMENT COMPANY LIMITED

UCH GAS FIELD, DERA BUGTI-BALOCHISTAN

TERMS AND CONDITIONS (TECHNICAL):-

1. The supplier/manufacturer must have past 5 years' experience in supplying the same nature of products in Oil and Gas sector, petrochemical and/or Oil refineries. Bidders to provide documentary proof, in the form of previous Purchase orders, with Technical bids.
2. Bidder/Supplier should quote gasket of Klinger, Flexitallic, Thermoseal, Jeil or any equivalent brand with UK/European/Korean/USA/Hong Kong/Indonesia/UAE origin.
3. Bidder shall provide Customer Satisfactory report along-with previous history of purchase orders of the quoted brand supplied to large organizations/corporations related to petrochemical/oil & gas industry inside Pakistan with technical bid.
4. Delivery period for material should not be more than 08-10 weeks from the date of Purchase Order issuance.
5. Supplier shall submit Material Specification and Country of origin confirmation from OEM along with technical bid.
6. Material will be delivered at Uch Gas Field-OGDCL in original OEM packing.
7. Inspection of material will be carried out by the OGDCL rep. at Uch Gas Field.
8. Off spec and deteriorated items will be rejected during inspection and to be replaced by the supplier without any claim/charges.
9. Supplier to ensure standard performance guarantee of 6 months after receipt, inspection and acceptance of material.
10. Bids evaluation criteria will be full consignment wise on the basis of technical specs and delivery period.



OIL & GAS DEVELOPMENT COMPANY LIMITED

UCH GAS FIELD, DERA BUGTI-BALUCHISTAN

ANNEXURE-A-1

GENERAL TERMS AND CONDITIONS:

- A. BIDS MUST BE SUBMITTED UNDER **TWO ENVELOPES BIDDING SYSTEM** i.e. TECHNICAL & FINANCIAL BID SEPARATELY ON DUE DATE.
- B. FINANCIAL BIDS OF ONLY TECHNICALLY RESPONSIVE BIDDERS WILL BE OPENED PUBLICLY.
- C. AFTER TENDER OPENING "TECHNICAL BIDS" WILL BE REVIEWED. THE BIDS WILL BE BROUGHT TECHNICALLY AT PAR BY SEEKING CLARIFICATIONS. THE BIDDERS WILL **NOT** BE ASKED FOR ANY PRICE CHANGE IN THEIR FINANCIAL BIDS DUE TO CERTAIN CLARIFICATIONS AND SUBSEQUENT CHANGE IN THEIR TECHNICAL PROPOSALS. THE BIDDERS WILL **NOT** BE ALLOWED TO SUBMIT SUPPLEMENTARY PRICE PROPOSALS IN A SEPARATE SEALED ENVELOPE TO MAKE IT A PART OF THE ALREADY SUBMITTED UNOPENED FINANCIAL BIDS AND TO ADJUST THEIR QUOTED PRICE SUBSEQUENTLY AFFECTED DUE TO CHANGE IN TECHNICAL PROPOSALS.
- D. SEALED FINANCIAL BIDS OF TECHNICALLY NON-RESPONSIVE BIDDERS WILL BE RETURNED UN-OPENED.
- E. OGDCL RESERVES THE RIGHT TO REJECT ANY OR ALL THE BIDS WITHOUT ASSIGNING ANY REASON.
- F. PRICES MUST BE QUOTED IN PKR INCLUSIVE OF ALL TAXES AND DUTIES, INDICATING UNIT PRICE AND TOTAL BID PRICES. GST MUST BE QUOTED SEPARATELY ALONG WITH COPY OF GST CERTIFICATE.
- G. QUOTED PRICES SHALL BE VALID FOR **90 DAYS** FROM THE OPENING DATE OF THE TECHNICAL BID.
- H. OGDCL RESERVES THE RIGHT TO EVALUATE THE BID(S) EITHER ITEM-WISE OR FULL PASKAGE BASIS WITHOUT ASSIGNING ANY REASON. TO QUOTE COMPETITIVE PRICES FOR ALL OR ANY ITEMS ENABLE COMPANY TO DECIDE PURCHASE.
- I. THE MAXIMUM DELIVERY TIME FOR SUPPLY ITEMS IS **08 - 10 WEEKS** FROM THE DATE OF RECEIPT OF FIRM PURCHASE ORDER.
- J. BIDDERS TO SUBMIT THEIR COMPANY PROFILES, EXPERIENCE OF SIMILAR SUPPLIES IN PAKISTAN ALONG WITH TECHNICAL BIDS.
- K. THE MASTER SET OF TENDER DOCUMENTS (LOCAL) AVAILABLE ON OGDCL WEBSITE (WWW.OGDCL.COM) IS THE INTEGRAL PART OF THIS TENDER.



OIL & GAS DEVELOPMENT COMPANY LIMITED

UCH GAS FIELD, DERA BUGTI-BALUCHISTAN

SCHEDULE OF REQUIREMENT Mandatory Checklist

Please confirm the compliance of the following mandatory information along with the bid(s) failing which bid(s) will not be accepted.

Documents	To be attached with the Technical / Financial Bids	Compliance	
		Yes <input type="checkbox"/>	No <input type="checkbox"/>
Original Bid Bond	Technical Bid	Yes <input type="checkbox"/>	No <input type="checkbox"/>
Copy of NTN Certificate	Technical Bid	Yes <input type="checkbox"/>	No <input type="checkbox"/>
Copy of GST Certificate	Technical Bid	Yes <input type="checkbox"/>	No <input type="checkbox"/>
Confirmation that the Firm is appearing FBR's Active Taxpayer List	Technical Bid	Yes <input type="checkbox"/>	No <input type="checkbox"/>
Duly Signed and Stamped Annexure-A(Un-priced)	Technical Bid	Yes <input type="checkbox"/>	No <input type="checkbox"/>
Duly filled, signed and stamped Annexure-B	Technical Bid	Yes <input type="checkbox"/>	No <input type="checkbox"/>
Duly filled, signed and stamped Annexure-D	Technical Bid	Yes <input type="checkbox"/>	No <input type="checkbox"/>
Duly signed and stamped Annexure-L on Company's Letter Head	Technical Bid	Yes <input type="checkbox"/>	No <input type="checkbox"/>
Duly signed and stamped Annexure-M on Company's Letter Head	Technical Bid	Yes <input type="checkbox"/>	No <input type="checkbox"/>
Duly signed and stamped Annexure-N on Non-Judicial Stamp paper duly attested by Notary Public	Technical Bid	Yes <input type="checkbox"/>	No <input type="checkbox"/>
Duly Filled, signed and stamped Annexure-A (Priced)	Financial Bid	Yes <input type="checkbox"/>	No <input type="checkbox"/>
Duly Filled, signed and stamped Annexure-C	Financial Bid	Yes <input type="checkbox"/>	No <input type="checkbox"/>
Duly Filled, signed and stamped Annexure-E	Financial Bid	Yes <input type="checkbox"/>	No <input type="checkbox"/>

The above Annexures are available in MASTER SET OF TENDER DOCUMENTS (LOCAL) and can be downloaded from OGDCL website (www.ogdcl.com).

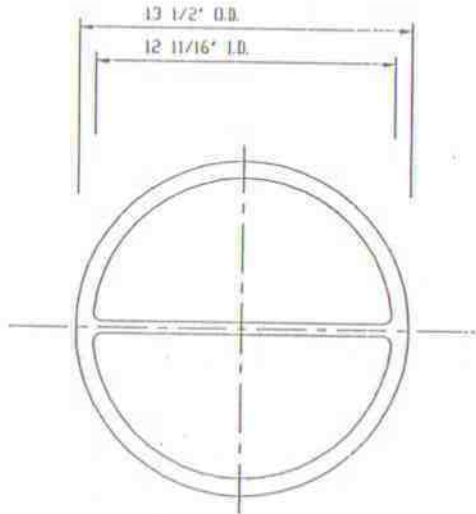

✓ (1)-REQUIRED.
CHANNEL GASKET,
1/8" THK 31603 SS DJ NAF
RIB WIDTH TO BE 5/16" WIDE.

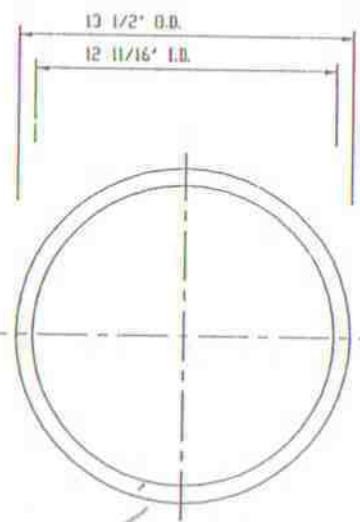

✓ (1)-REQUIRED.
SHELL GASKET,
1/8" THK 31603 SS DJ NAF

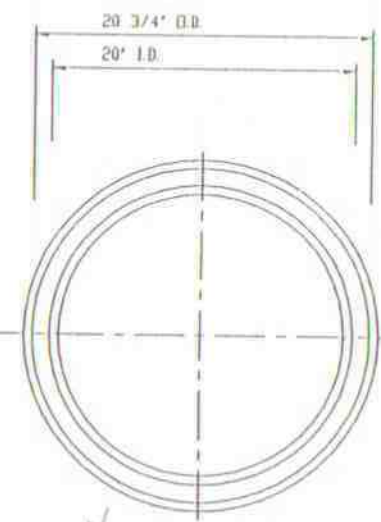

✗ (1)-REQUIRED.
MANWAY GASKET
.175" THK 31603 SS FLEXITALLIC (A)

===== COMPRESSION RINGS =====

- (A) 21.2500 O.D. X .1250 THICK; MATERIAL=SA-240-31603
- 19.5000 I.D. X .1250 THICK; MATERIAL=SA-240-31603

NOTES:

- 1) QUANTITIES SHOWN FOR ONE SET
- (1)-SET REQUIRED PER UNIT
- 2) ALL RADII TO BE 1/4"

Boiler

MRP NBC 9269
Wone

			GASKET DETAILS	
			OWN. BY	 JOY INDUSTRIES PTE LTD SINGAPORE
			KS	
			DATE	
			11-28-96	
			CKD. BY	DVGHD
			DA	2074A-D
0	12-1	FOR APPROVAL		
NO.	DATE	REVISIONS		

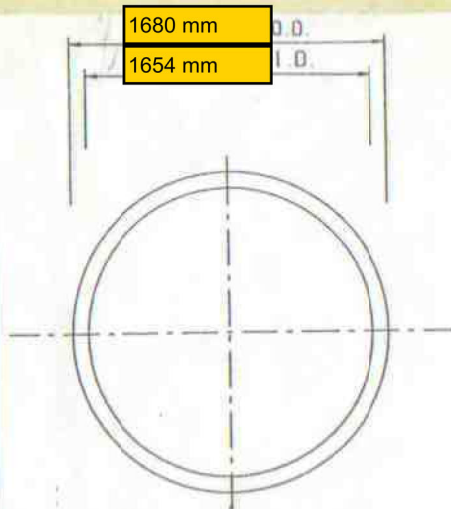

④ ONE (1) - REQUIRED
 FRONT CHANNEL COVER GASKET
 1/8" THK. STL. DOUBLE JACKETED
 W/ FLEXIBLE GRAPHITE FILLER.

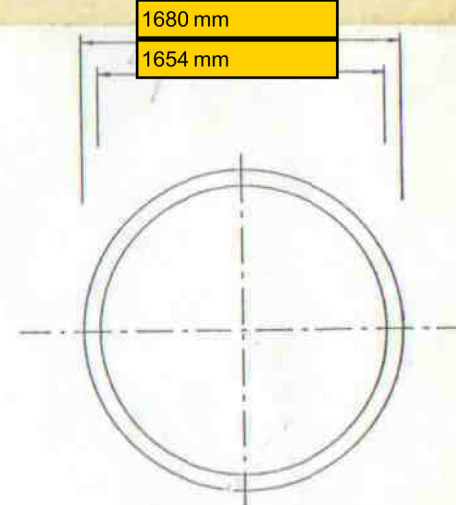

④ ONE (1) - REQUIRED
 REAR CHANNEL COVER GASKET
 1/8" THK. STL. DOUBLE JACKETED
 W/ FLEXIBLE GRAPHITE FILLER.

NOTES:

- 1) QUANTITIES SHOWN FOR ONE (1) SET
 THREE (3) SETS REQUIRED TOTAL.
- ONE (1) SET OF GASKETS TO BE USED IN EXCH. AND
 TWO (2) SETS TO BE BOXED, MARKED WITH
 P.O. & ITEM NO. & SHIPPED WITH EXCHANGER.
- 2) ALL JACKETED GASKETS TO HAVE
 LAP OF GASKET NEAR SIDE.

					CUSTOMER: PETROSIN
					OHMSTEDE JOB NO.: 658313
					P.O. NO.: P181/8882
					ITEM NO.: 18-E-201/20-E-201
					SERVICE: AMINE STRIPPER REBOILER
					(2) UNITS REQ'D.
1	RELEASE FOR FABRICATION	MS	DC	3-7-97	GASKET DETAILS
2	FOR CUSTOMER APPROVAL	JASS	DC	1-7-97	
NO	REVISIONS	BY	CHK.	DATE CHK.	OHMSTEDE
					DRAWING NO. 658313
					SHEET NO. 12
					REV. 1

4

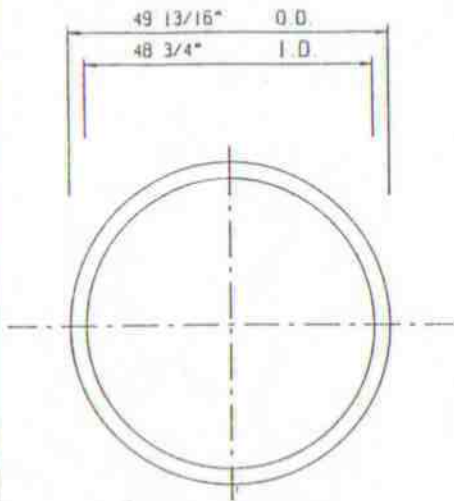

⚠ (48) ONE (11) - REQUIRED
 FRONT CHANNEL COVER GASKET
 1/8" THK. SOFT STL. DOUBLE JACKETED
 W/ FLEXIBLE GRAPHITE FILLER.

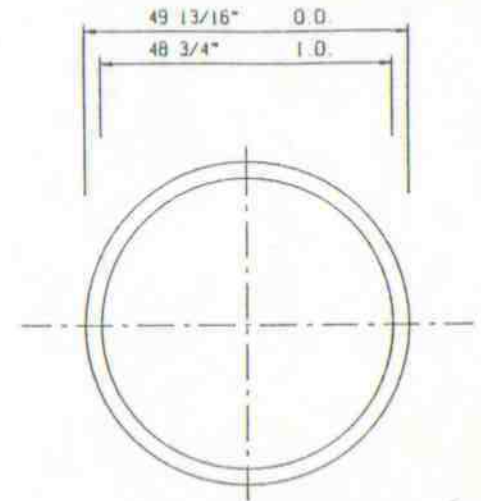

⚠ (48) ONE (11) - REQUIRED
 REAR CHANNEL COVER GASKET
 1/8" THK. SOFT STL. DOUBLE JACKETED
 W/ FLEXIBLE GRAPHITE FILLER.

- ⚠ NOTES:
- 1) QUANTITIES SHOWN FOR ONE (11) SET
 THREE (3) SETS REQUIRED TOTAL.
 ONE (11) SET OF GASKETS TO BE USED IN EXCH. AND
 TWO (2) SETS TO BE BOXED, MARKED WITH
 P.O. & ITEM NO. & SHIPPED WITH EXCHANGER
 - 2) ALL JACKETED GASKETS TO HAVE
 LAP OF GASKET NEAR SIDE.

					CUSTOMER: PETROSIN			
					OHMSTEDE JOB NO.: 658315			
					P.O. NO.: P181/0802			
					ITEM NO.: 18-E-283/28-E-283 121 UNITS REQ'D.			
					SERVICE: AMINE SOLUTION COOLER			
1	RELEASE FOR FABRICATION	HS	DC	3-18-97	GASKET DETAILS			
8	FOR CUSTOMER APPROVAL	JUSS	DC	1-14-97				
NO.	REVISIONS	BY	CHK.	DATE CHK	OHMSTEDE	DRAWING NO. 658315	SHEET NO. 12	REV. 1

35

SHELL SIDE GASKET

N°1 PIECE

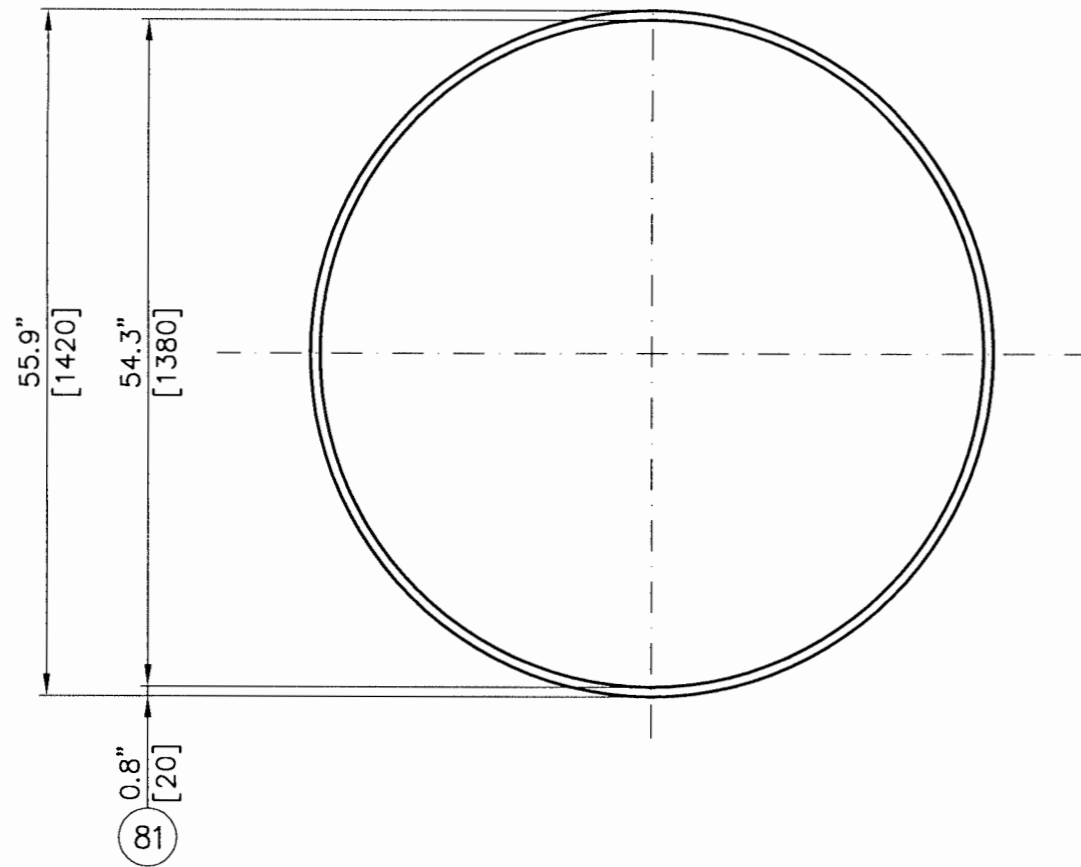

TUBE SIDE GASKET

N°1 PIECE

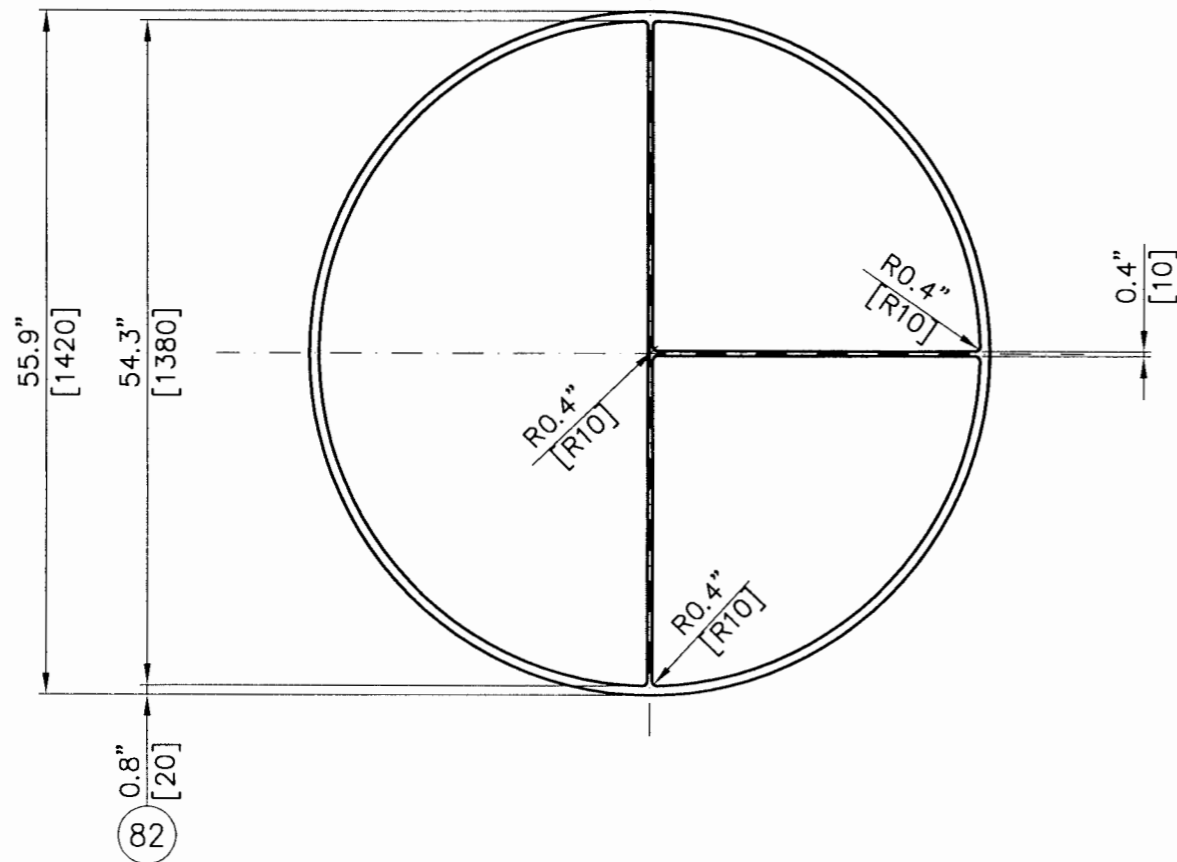

SICES ENGINEERING DEPARTMENT	
DOCUMENT STATE Stato Documento	DATE Data
PRELIMINARY PRELIMINARE	<input type="checkbox"/>
VALID FOR MATERIALS PURCH. VALIDO PER ACQ MATERIALI	<input type="checkbox"/>
VALID FOR CONSTRUCTION VALIDO PER COSTRUZIONE	<input checked="" type="checkbox"/>
ASME CONSTRUCTION DTF ENG N° (FOR INTERNAL DISTRIBUTION ONLY)	

01	25.02.13	ISSUED FOR CONSTRUCTION	EDI	M.Maroni	F.Andrigo	M.Corò
00	01.02.13	ISSUED FOR APPROVAL	EDI	M.Maroni	F.Andrigo	M.Corò
REV. Rev.	DATE Data	DESCRIPTION Descrizione	DRAWN Disegnato	CHECKED Contr.	CMS Visto CMS	APPROVED Approvato

SICES LONATE CEPPINO (VA)-ITALY	PURCHASE Committente	JOB No. Commessa
ORDER No. N. Ordine	12AA0272	
USER- Utente	OGDCL - Oil & Gas Development Company Limited	DRAWING Disegno 7213-09
PLANT LOCATION- Località	PAKISTAN	FILE File DWG-7213-09-Rev01-Gaskets
PROJECT- Progetto	UCH-II Development Project	SERIAL NUMBER N. di fabbrica
SERVICE- Servizio	REGENERATOR REBOILER	7213 A÷D

ITEM: 300/310 E103A/B (GASKETS DETAILS)		SCALE Scala 1:15	SHEET Foglio 9	OF di ...
All right of this drawing are reserved Questo disegno è vincolato a norma di legge		SIZE Form. A3		

ENAR ENAR PETROTECH SERVICES (PRIVATE) LTD. Job 14-4985
 A COMPANY OF TEL:5062791 FAX:5067522 KARACHI-PAKISTAN

OIL & GAS DEVELOPMENT COMPANY LTD

01	ISSUED FOR APPROVAL	EDI	M.Maroni	M.Corò	25-02-2013
00	ISSUED FOR COMMENTS	EDI	M.Maroni	M.Corò	01-02-2013
REV.	DESCRIPTION	DRAWN	CHECKED	APPROVED	DATE

BELLELLI ENGINEERING S.p.A.
 Badia Polesine (RO) - ITALIA
 Via Meucci 232
 Tel +390425 595074 Fax +390425 590372
 Licensed PRISM membrane OEM of **AIR PRODUCTS**

DOC TYPE:	DOCUMENT NO.
CONSTRUCTION DRAWINGS FOR REGENERATOR REBOILER (300/310-E103A/B)	3-E103-ME-DW-004

CONTRACTOR DOCUMENT NO.	LOCATION	PLANT	SCALE	SHEET	REV. NO.
1896-12	PAKISTAN	REGENERATOR REBOILER	1:15	8 OF 9	01

D

C

B

A

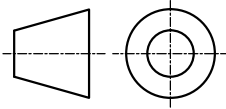

		ENAR PETROTECH SERVICES (PRIVATE) LTD. TEL: 5062791 FAX: 5067822 KARACHI-PAKISTAN		Job No. 14-4985	
OIL & GAS DEVELOPMENT COMPANY LTD.					
01	ISSUED FOR APPROVAL				2013.5.16
REV	DESCRIPTION	DRAWN	CHECKED	APPROVED	DATE
		BELLELLI ENGINEERING S.p.A. Via Antonio Meucci 232 - 45021 BADIA POLESINE (RO) Tel. 0039.0425.595.074 - Fax. 0039.0425.590.372 www.bellelliteng.com / info@bellelliteng.com		UCH-II DEVELOPMENT PROJECT	
DOCUMENT TYPE				DOCUMENT NUMBER	
CONSTRUCTION DRAWING FOR (300/310-E112) GASKET				3-E112-ME-DW-010 SHEET 4	
BELLELLI PROJECT CODE	LOCATION	PLANT	SCALE	SHEET	REV.N.
1896-12	PAKISTAN	AMINE GAS SWEETENING UNIT	-	4 of 25	01

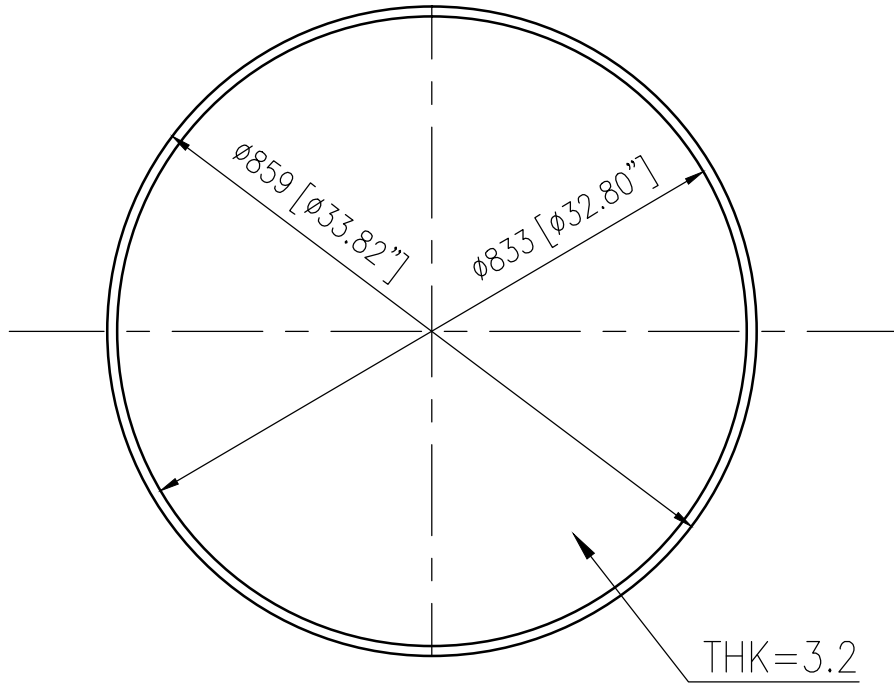

1		GASKET Ø859/Ø833x3.2	1	KAMMPROFIL			m=2 y=17.24MPa
PART NO.	DWG OR STANDARD NO.	DESCRIPTION	QTY.	MATERIAL	WEIGHT(kg)		REMARKS
					SNGE	TOTAL	
			YY / MM / DD	YY / MM / DD	YY / MM / DD	YY / MM / DD	YY / MM / DD
	ISSUED FOR APPROVAL						
			YY / MM / DD	YY / MM / DD	YY / MM / DD	YY / MM / DD	YY / MM / DD
REV.	DESCRIPTION	DESIGN	CHECK	STANDARDIZATION	REVIEW	APPROVE	
REVISIONS							
PROJECT		BELLELLI ENGINEERING S.p.A.		OIL & GAS DEVELOPMENT COMPANY LTD.		GASKET	
PRODUCT NO.	C13-014-3A/B	EQUIPMENT	TREATED GAS COOLER		DRAWING NO.	3-E112-ME-DW-010 SHEET 4	
				BEKL ENERGY PROCESS SYSTEM BERHAD	STAGE		SPECI
				SCALE	NO SCALE	1 OF 1	

This drawing is the property of BEKL ENERGY PROCESS SYSTEM BERHAD and must be used confidentially, is not to be reproduced, distributed without the written permission of an officer of BEKL ENERGY PROCESS SYSTEM BERHAD.

D

C

B

A

D

C

B

A

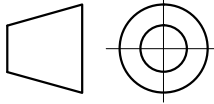

**ENAR PETROTECHSERVICES
(PRIVATE) LTD.**
A COMPANY OF ENAR
TEL:5062791 FAX:5067522 KARACHI-PAKISTAN

Job No. 14-4985



OIL & GAS DEVELOPMENT COMPANY LTD.

01	ISSUED FOR APPROVAL				2013.15
00	ISSUED FOR APPROVAL				
REV	DESCRIPTION	DRAWN	CHECKED	APPROVED	DATE



BELLELLI ENGINEERING S.p.A.
Via Antonio Maurici 232 - 45021 BADIA POLESINE (RO)
Tel. 0039.0425.595.074 - Fax. 0039.0425.590.372
www.bellellieng.com / info@bellellieng.com

UEH-II
DEVELOPMENT PROJECT

DOCUMENT TYPE				DOCUMENT NUMBER	
Rear Channel Gasket				3-E113-ME-DW-011-009	
BELLELLI PROJECT CODE	LOCATION	PLANT	SCALE	SHEET	REV No.
1896-12	PAKISTAN	AMINE GAS SWEETENING UNIT	-	9 of 18	01

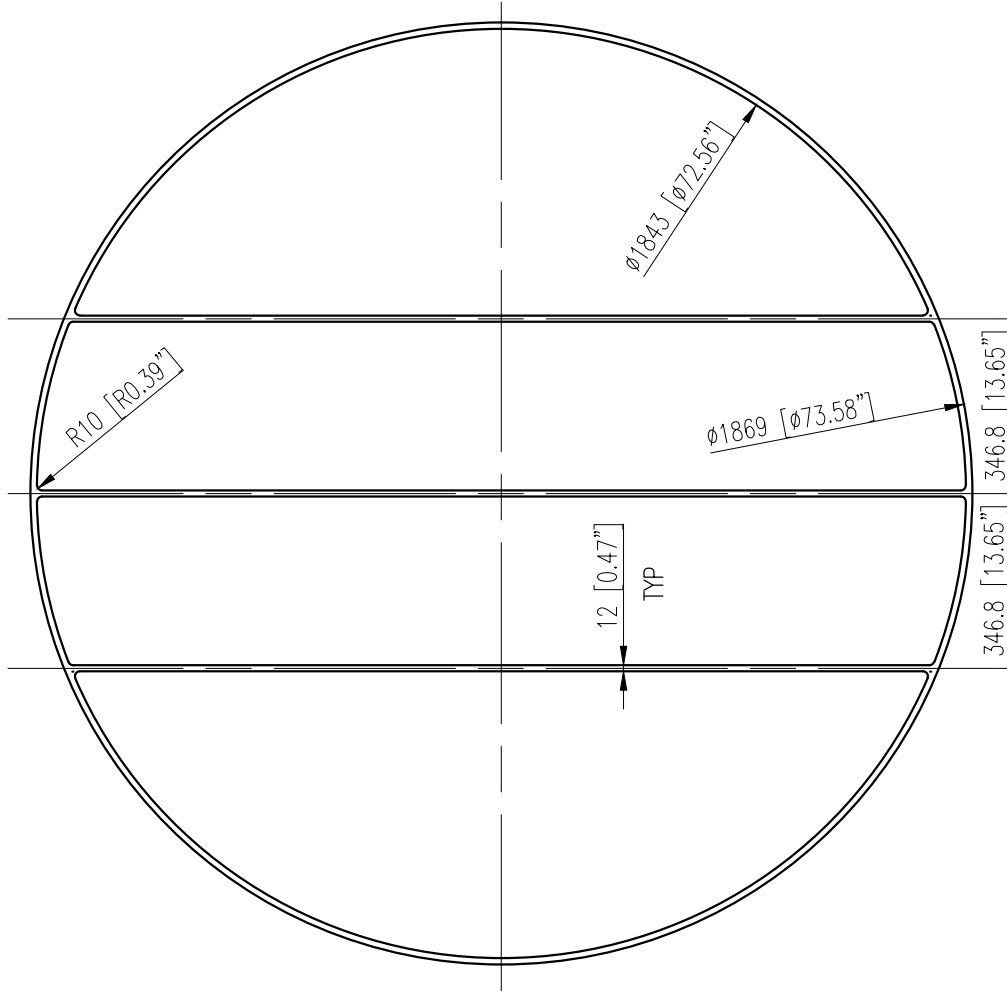

PART NO.	DWG OR STANDARD NO.	DESCRIPTION	QTY.	MATERIAL	WEIGHT (Kg)		REMARKS
					SINGLE	TOTAL	
1		Gsaket THK=3.2	1	Kammprofil			m=2;y=17.24
2							
1		issued for approval					
REV.	DESCRIPTION	DESIGN	CHECK	STANDARDIZATION	REVIEW	APPROVE	

REVISIONS

PROJECT	BELLELLI ENGINEERING SpA	OIL & GAS DEVELOPMENT COMPANY LTD.	Rear Channel Gasket		
PRODUCT NO.	C13-014-4A/B	EQUIPMENT	Lean Amine Trim Cooler	DRAWING NO.	3-E113-ME-011-009
BEKL ENERGY PROCESS SYSTEM BERHAD	STAGE		SPECI		
	SCALE	NO SCALE			1/1 OF

This drawing is the property of BEKL ENERGY PROCESS SYSTEM BERHAD and must be used confidentially, is not to be reproduced, distributed without the written permission of an officer of BEKL ENERGY PROCESS SYSTEM BERHAD.

D

C

B

A

D

C

B

A

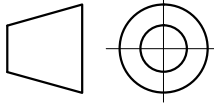

ENAR PETROTECHSERVICES (PRIVATE) LTD.		Job No. 14-4985
TELEPHONE: 0093-225-582474 FAX: 0093-225-582477		
OIL & GAS DEVELOPMENT COMPANY LTD.		
DR	ISSUED FOR APPROVAL	2013/3
RE	ISSUED FOR APPROVAL	
REV	DESCRIPTION	DRAWN CHECKED APPROVED DATE
BELLELLI ENGINEERING S.p.A.		UG-4 DEVELOPMENT PROJECT
Via. Anversa, 10000 221 - 22021 BAZZA (PESCARA) (PD) Tel. 0039-0429-25582474 Fax: 0039-0429-25582477 www.bellelliengineering.com info@bellellieng.com		DOCUMENT NUMBER
Project Owner: Shell		3-E113-ME-DW-011-016
ILLUSTRATION	LOCATION	PLANT
096-02	PAKISTAN	AMINE GAS SWEETENING UNIT
	SCALE	SHEET / REV NO.
		1 / 1 0

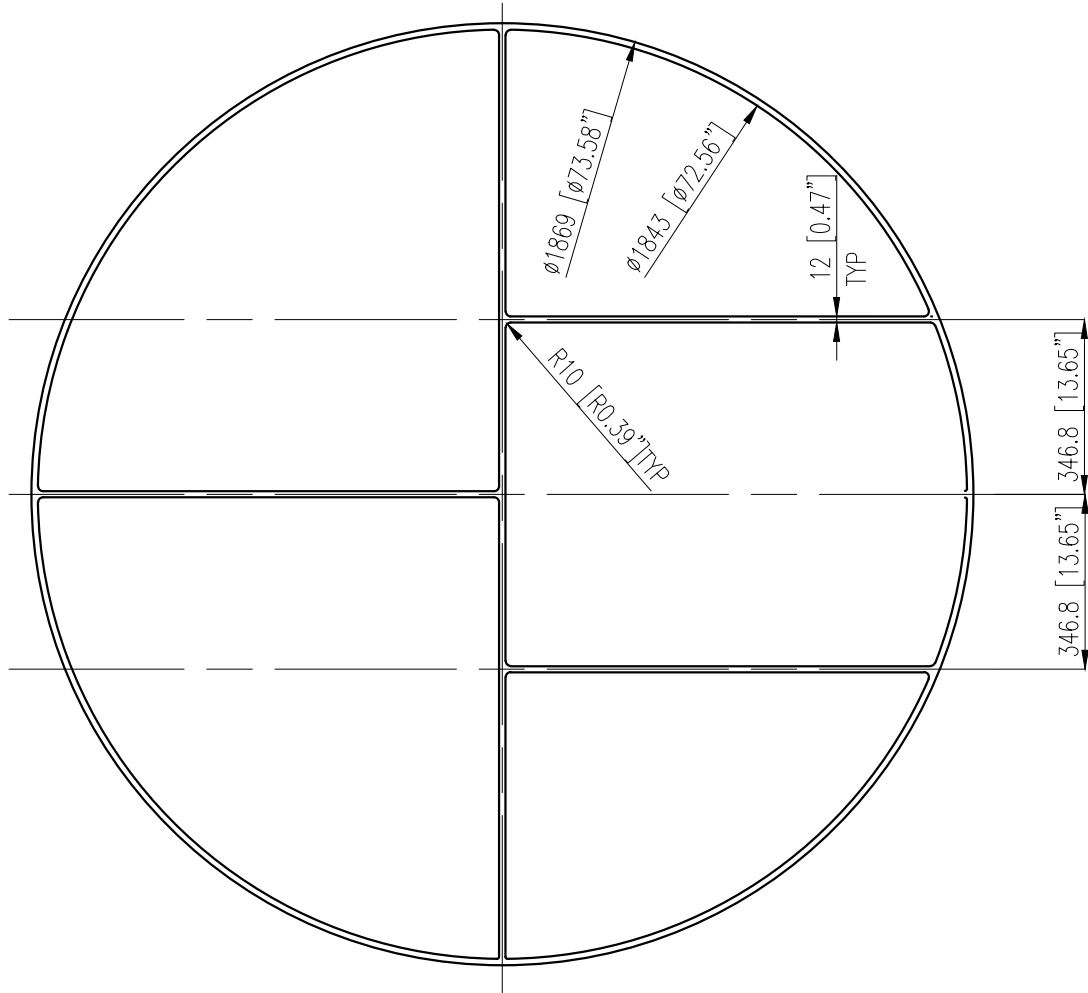

1		Gsaket THK=3.2	1	Kammprofil			m=2;y=17.24
PART NO.	DWG OR STANDARD NO.	DESCRIPTION	QTY.	MATERIAL	WEIGHT (Kg)		REMARKS
					SINGLE	TOTAL	
	issued for approval						
REV.	DESCRIPTION	DESIGN	CHECK	STANDARDIZATION	REVIEW	APPROVE	
REVISIONS							
PROJECT	BELLELLI ENGINEERING SpA	OIL & GAS DEVELOPMENT COMPANY LTD.	Front Channel Gasket				
PRODUCT NO.	C13-014-4A/B	EQUIPMENT	Lean Amine Trim Cooler	DRAWING NO.	3-E113-ME-DW-011-016		
	BEKL ENERGY PROCESS SYSTEM BERHAD			STAGE		SPECI	
				SCALE	NO SCALE		1/1 OF

This drawing is the property of BEKL ENERGY PROCESS SYSTEM BERHAD and must be used confidentially, is not to be reproduced, distributed without the written permission of an officer of BEKL ENERGY PROCESS SYSTEM BERHAD.

D

C

B

A

D

C

B

A

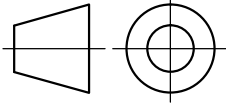

ENAR PETROTECH SERVICES
(PRIVATE) LTD.
TEL: 5062791 FAX: 5067832 KARACHI-PAKISTAN

Job No. 14-4985



OIL & GAS DEVELOPMENT COMPANY LTD.

01	ISSUED FOR APPROVAL				2013.5.15
REV.	DESCRIPTION	DRAWN	CHECKED	APPROVED	DATE



BELLELLI ENGINEERING S.p.A.
Via Antonio Meucci 232 - 45021 BADIA POLESINE (PD)
Tel. 0039.0425.595.074 - Fax. 0039.0425.590.372
www.bellellieng.com / info@bellellieng.com

UCH-II
DEVELOPMENT PROJECT

DOCUMENT TYPE		DOCUMENT NUMBER	
GASKET		3-E114-ME-DW-012 SHEET 3	
BELLELLI PROJECT CODE	LOCATION	PLANT	SCALE SHEET REV. NO.
1896-12	PAKISTAN	AMINE GAS SWEETENING UNIT	- 3of19

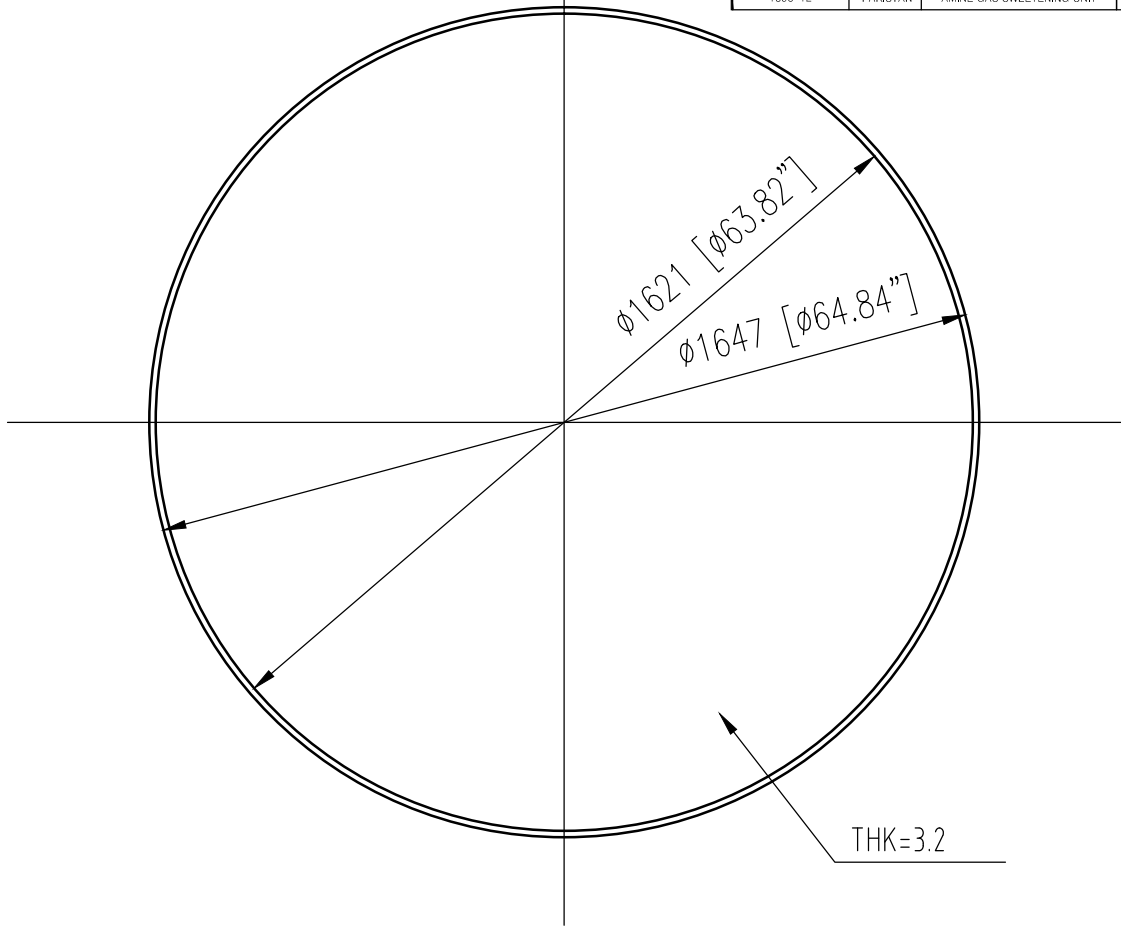

1		GASKET	$\phi 1621/\phi 1647 \times 3.2$	1	KAMMPROFIL			m=2 y=17.24 MPa
PART NO.	DWG OR STANDARD NO.	DESCRIPTION	QTY.	MATERIAL	WEIGHT (kg)		REMARKS	
					SINGLE	TOTAL		
	ISSUED FOR APPROVAL							
REV.	DESCRIPTION	DESIGN	CHECK	STANDARDIZATION	REVIEW	APPROVE		
REVISIONS								
PROJECT	BELLELLI ENGINEERING S.p.A.	OIL & GAS DEVELOPMENT COMPANY LTD.	GASKET PART					
PRODUCT NO.	C13-014-5A/B	EQUIPMENT	REGENERATOR CONDENSER	DRAWING NO.	3-E114-ME-DW-012 SHEET 3			
	BEKL ENERGY PROCESS SYSTEM BERHAD			STAGE		SPECI		
		SCALE	NO SCALE	1 OF 1				

This drawing is the property of BEKL ENERGY PROCESS SYSTEM BERHAD and must be used confidentially, is not to be reproduced, distributed without the written permission of an officer of BEKL ENERGY PROCESS SYSTEM BERHAD.

D

C

B

A

GLYCOL RE-BOILER (MAIN BUNDLE) GASKET

ITEM 15 : DETAIL OF GASKET (N° 8 PASSES)

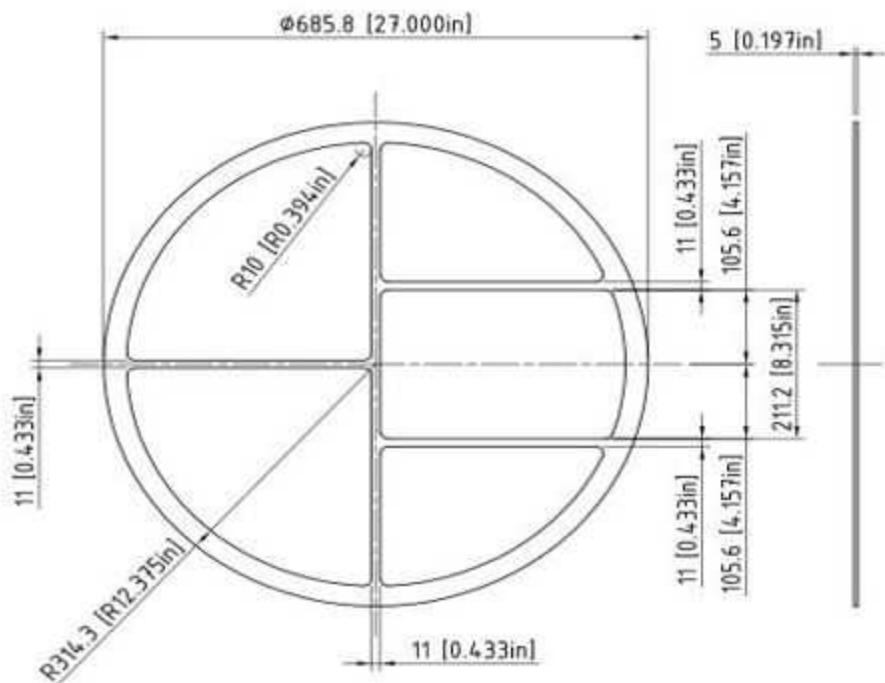

15	1	GASKET	SEE DETAIL	GRAPHITE	-	-	-	-
13	1	GASKET	[24-150-316L-F.G.]	316L SS	-	-	[B16.20]	-