

**OIL & GAS DEVELOPMENT COMPANY LIMITED**  
**PROCUREMENT DEPARTMENT, ISLAMABAD**  
**FOREIGN SECTION C**

(To be completed, filled in, signed  
and stamped by the principal)

**ANNEXURE 'A'**

**Material** DESIGN & SUPPLY OF COOLING TOWERS (COMPLETE PACKAGE) INCLUDING INSTALLATION/COMMISSIONING  
**Tender Enquiry No** ASSISTANCE AT DAKHNI PLANT.  
**Due Date** PROC-FC/CB/P&P/DKN-4612/2020  
**Evaluation Criteria** FULL

**SCHEDULE OF REQUIREMENT**

Sr No	Description	Unit	Quantity	Unit Price (FOB)	Total Price (FOB)	Unit Price C & F BY SEA	Total Price C & F BY SEA	Deviated From Tender Spec. If Any
1	COOLING TOWER (COMPLETE PACKAGE) AS PER ATTACHED TOR	Number	3					
2	TWO YEARS SPARES	Number	1					
3	INSTALLATION AND COMMISSIONING ASSISTANCE AS PER ATTACHED TOR	Number	1					

**Note:**

**Note:** Bidders are advised that Payment will be made as per the Foreign Procurement Payment Terms available at OGDCL Website (Tenders Tab) effective from February 27, 2018.

- 1) PURSUANT TO TENDER CLAUSE # 2.2, 11.4, 13 & 35.3.2, BID BOND AMOUNTING TO USD 2250/- OR EQUIVALENT TO PAK RUPEES MUST BE SUBMITTED WITH THE TECHNICAL BID AND VALID FOR 150 DAYS FROM THE DATE OF OPENING OF THE BID.
- 2) **TOR:** ATTACHED TOR IS INTEGRAL PART OF SOR.
- 3) **EVALUATION CRITERIA:** FULL CONSIGNMENT WISE ON CFR BY SEA KARACHI BASIS.
- 4) **TERMS AND CONDITIONS:** BIDDERS ARE ADVISED TO CAREFULLY READ ALL THE TERMS AND CONDITIONS OF THE TENDER DOCUMENT AVAILABLE AT OGDCL WEBSITE IN THE MASTER TENDER DOCUMENT. COMPLETE ORIGINAL BID WITH ALL ANNEXURES DULY SIGNED AND STAMPED BY BIDDER BE SUBMITTED.

**Design and Supply of 03 No's of Cooling Tower (Complete Package) Including Installation  
Commissioning Assistance for Dakhni Plant**

Supplier/ bidder/ manufacturer is required to size the Cooling Tower, select the instrumentation, supply the material, ship, assemble, install and Commission the cooling tower at Dakhni and give the best performance guarantee.

**1- Design Basis :**

Type	Induce Draft, Cross Flow, Square Shape
Ambient temperature	51°C Max
Entering Water Temperature	46°C
Leaving Water Temperature	35°C
Water Flow through each cooling tower	114 m <sup>3</sup> /hr (502 US GPM)
Wet Bulb Temperature	28.3 °C
Recommended Material (Frame/ Bolts/ Ladder/ Inner Structure/ Motor Support)	Stainless Steel 316
Recommended Material Nozzles	High Quality ABS (Acrylonitrile butadiene styrene)
Fills Sheet & Drift Eliminator	High Quality Improved PVC
Casing panel, Basin, Access Door	High Intensity FRP (Fiber-Reinforced Plastic)
Fan Cylinder, Sump	High Intensity FRP
Fan (Adjustable pitch)	Aluminum Alloy
Fan Drive	Belt Drive
Sheave Material	VTS (Vendor to Specify)
Water inlet/outlet flanges	SA-106/105(NACE Compliance)

**2- Specification of Fan Motor:**

The motor should be capable of developing sufficient horse power to drive the fan at full load at maximum site ambient conditions.

3 phase, 415 V, 50 HZ, **VTS** RPM, able to perform at 51 °C ambient temp, Enclosure: IP-55, insulation Class = F, Explosion Proof Motor = EEXD IIB T4. Direction of rotation: unidirectional. Power factor: 0.8, Connection: Star, Termination VTS, and Method of starting: direct.

**Note: Foundation drawing of the already installed cooling tower is attached for reference for design and quote of new cooling towers.**

## TERMS OF REFERENCES:

1. Bidder/ packager must provide the authorization letter from the cooling tower manufacture to participate in the subjected tender enquiry.
2. The Quoted Cooling Tower model and brand must be CTI (Cooling Technology Institute) certified.
3. Valid CTI Certification copy should be provided with the bid.
4. The Cooling Tower should be horizontal skid mounted with all necessary required instrumentation and mechanically acceptable. Preferably foundation layout for cooling tower feet is attached with the TOR. Bidder to confirm tentative sizes of cooling tower in technical bid.
5. Bidder/Manufacturer/ Packager will be responsible for design,fabrication&Supply of Cooling Tower Complete in all respects as per provided parameter.
6. Design should be based on corrosive environment.
7. **Bidder should provide the isometric and foundation drawing of package with the technical bid.** The brand (Worldwide Renowned), country of origin of package must be provided with the technical bid otherwise bid will not be further evaluated.
8. Manufacturer should have at least 10 years (2009~2019) of experience for design/manufacturing of Cooling Towers. Manufacturer having less than 10 years of experience will not be considered for evaluation.
9. Verifiable documents of previous supply, unpriced copy of contract / purchase order of Cooling Tower etc. with name and full contact details of clients to be provided in technical bid.
10. Complete foundation details / design to be provided. Foundation Civil drawings for construction of foundation will be in bidder and provided 02 months prior to shifting of cooling towers. Preparation of foundation is in OGDCL scope. Already installed cooling tower foundation layout is attached for reference.
11. As designing in bidder scope so if any design fault / system malfunctioning observed at the stage of testing and during commissioning, full rectification and replacement will be in bidder scope.
12. All the piping, nozzles, valves, all studs for connection, gaskets etc. up to battery limit of cooling tower is in bidder scope.

13. General Arrangement Drawings, detailed Engineering drawing and design calculation (02 sets of Hard/ Soft Copies) to be provided with supply.
14. **If bidder/ packager required any clarification, it should be cleared prior to 02 weeks from bid opening date.**
15. Bidder/manufacture/ packager will provide complete details of origin with the technical bid and MTC of materials should be submitted prior to its import for approval.
16. Certificate should be submitted that the installed items are brand new and their model and spares will not obsolete in next 10years.
17. Shipment of cooling tower package from manufacturer works is C&F by Sea Karachi basis
18. Execution Plan of Project should be submitted along the technical bid.
19. Bidder/ manufacturer/ packager to confirm Guarantee / warrantee for a period of 01 year after installation or 18 months after shipment, whichever completes earlier.
20. Bidder must provide assembling, installation and commissioning assistance at Dakhni Plant. The services cost must be included in the equipment total cost on lump sum basis.
21. Crane at site will be provided by OGDCL. Placement tightening alignment and testing/ commissioning of cooling tower at OGDCL site (Dakhni Plant Tehsil Jand District Attock) ion contractor scope.
22. Cabling upto battery limit of cooling tower is in OGDCL scope
23. Painting of complete package, as per standard / code requirement is in bidder scope.
24. **Delivery time:** 06 months after LC.
25. **Payment Terms:**
  - I. 70% Payment after shipment through LC
  - II. 30% after receipt of material, inspection and successful installation/commissioning at OGDCL site (Dakhni Plant) through LC.

**Technical Evaluation Criteria**

**BIDDER/ MANUFACTURER MUST OBTAIN MINIMUM QUALIFYING MARKS IN EACH CATEGORY.**

Sr #	Evaluation Item	Max. Marks / Calculations	Max Marks	Min. Qualif ying Marks	Remarks	Remarks from Bidder
---------	-----------------	---------------------------------	--------------	---------------------------------	---------	------------------------

Sr . #	Evaluation Item	Max. Marks / Calculations	Max . Marks	Min. Qualif ying Marks	Remarks	Remarks from Bidder
1	Manufacturer Experience	15 Years (30 Marks) 10 Years (20 Marks) Less Than 10 Years= (Zero Marks)	30	20	(Bidder should provide evidence)	
2	Complete compliance of TOR	20 Marks	20	20	Bidder to confirm the compliance with separate letter.	
3	Previous Purchase Order for supply Cooling Towers between 2005 ~2019	Supply of 10 Cooling Towers (30Marks) Supply of 05 Cooling Towers (15 Marks) Less than 05 Zero Marks	30	15	Provide the purchase orders with their details	
4	CTI Certification.	10 Marks	10	10	Bidder/ Manufacturer should submit the valid copy of certificates. If the certificate status is in progress, no marks shall be given.	

Sr . #	Evaluation Item	Max. Marks / Calculations	Max . Marks	Min. Qualif ying Marks	Remarks	Remarks from Bidder
5	ISO 9001 Certification. PEC Registration	05 05	10	05	Bidder/ Manufacturer should submit the valid copy of certificates. If the certificate status is in progress, no marks shall be given.	
			100	70		

Note: For strict compliance bidder should clarify each point before submission of tender document through email or can visit Dakhni Gas Processing Plant.

**Financial Evaluation Criteria**

Sr No	Description	Quantity	Price in US\$
01	DESIGN AND SUPPLY OF COOLING TOWER (COMPLETE PACKAGE)	03	
02	INSTALLATION AND COMMISSIONING ASSISTANCE AT DAKHNI PLANT	01	
03	02 YEARS SPARES FOR THE PACKAGE (ITEM WISE LIST WITH UNIT COST TO BE PROVIDED)	01	

**Note: Financial evaluation will be against Sr#01& 02 only**

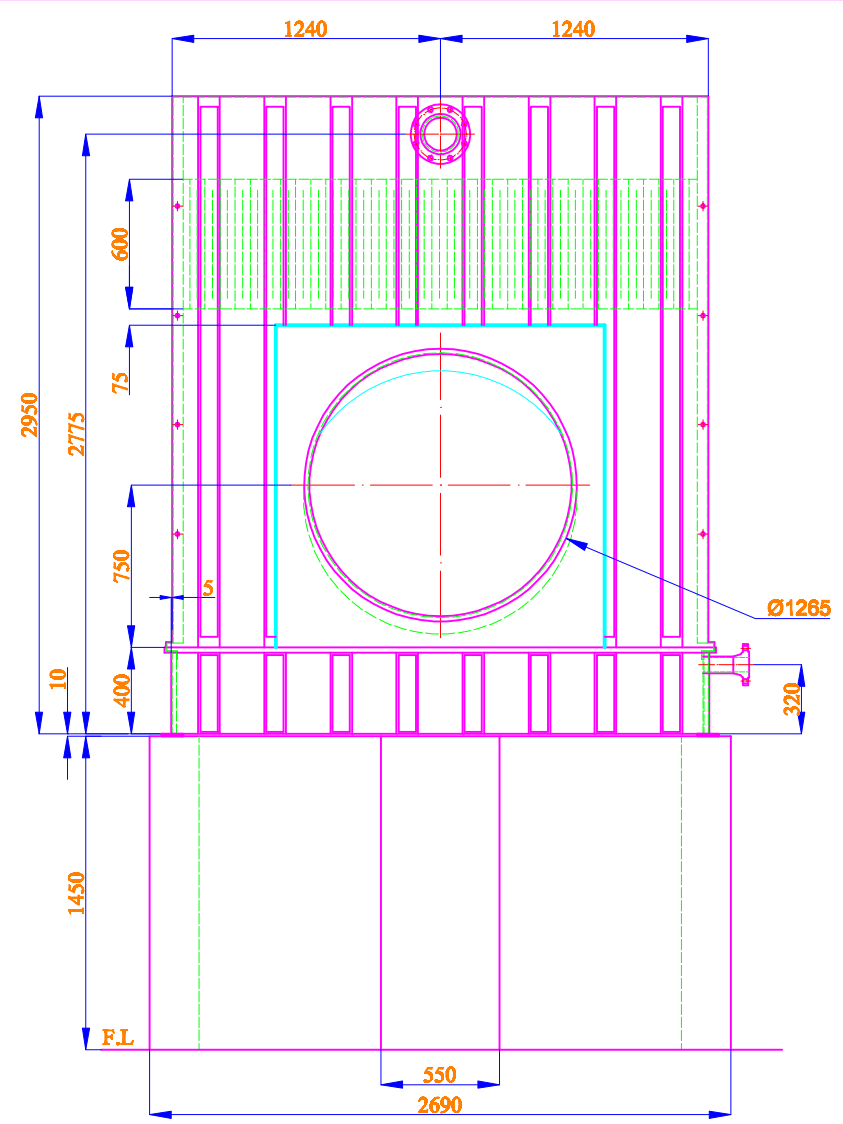

**ELEVATION**

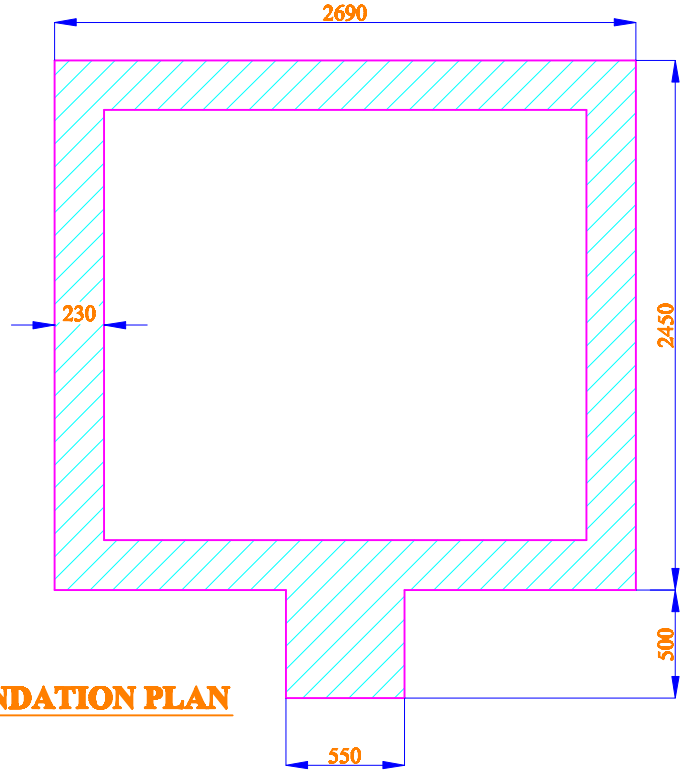

**FOUNDATION PLAN**

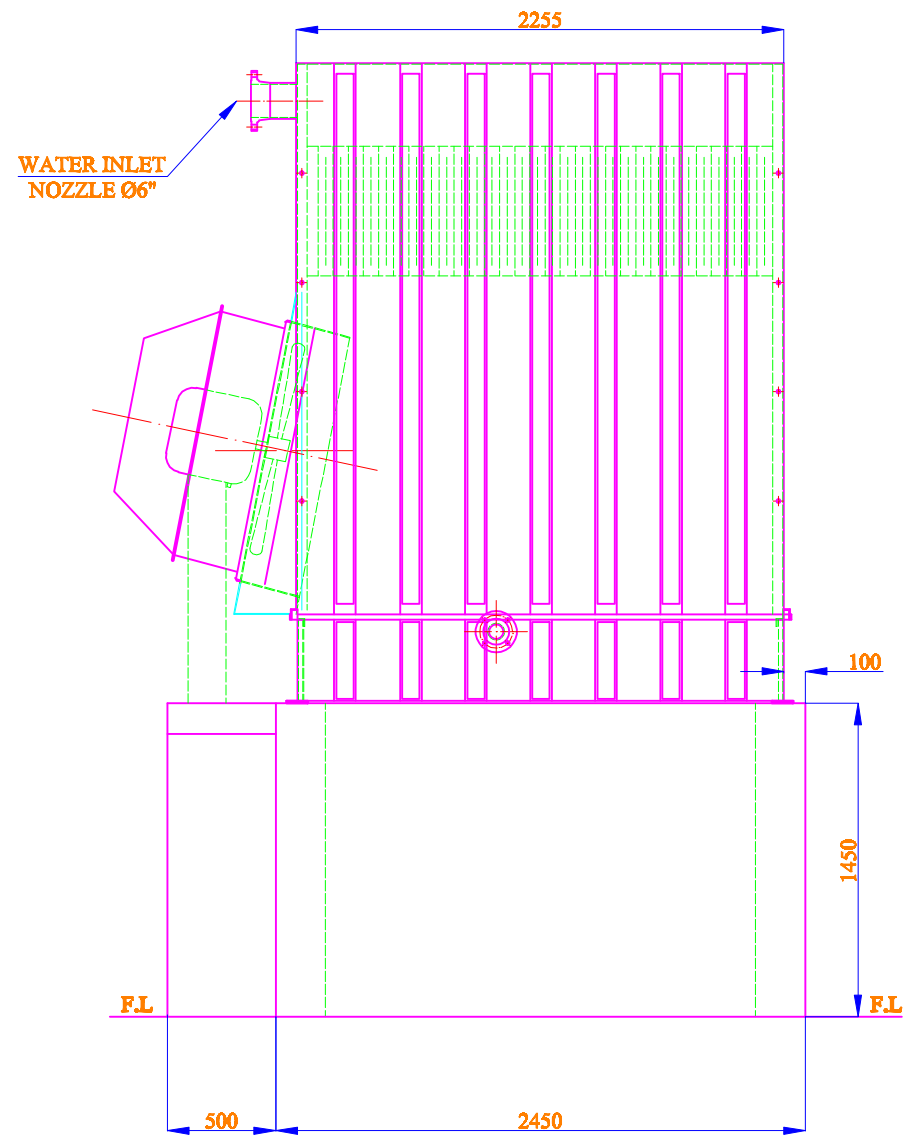

**ELEVATION**

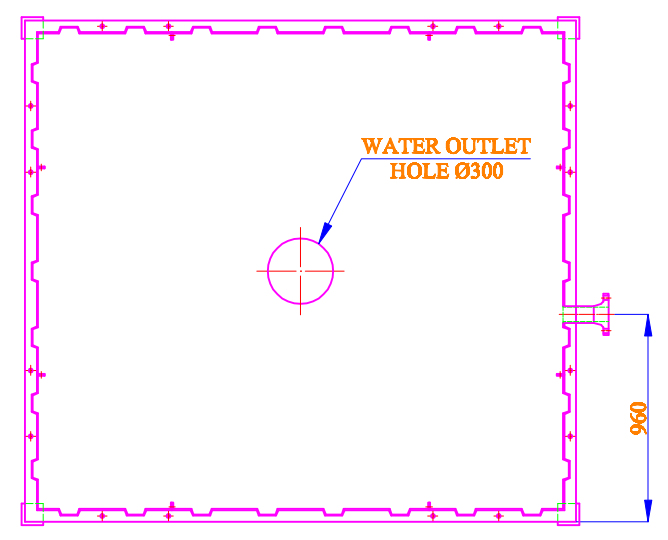

**COOLER BOTTOM DETAIL**

Rev. 0	Issue For Provisional			
Rev. No	Revision Note	Checked By	Checked By	Approved By
 <b>OIL &amp; GAS DEVELOPMENT COMPANY LTD.</b> <b>PROCESS &amp; PLANTS DEPARTMENT</b> <b>Dakhni Gas Processing Plant</b>				
<b>TITLE- Carter Cooling Tower Nozzle &amp; Foundation Dimension</b>				
CAD BY <i>M. Waqar Khalid</i> Draftsman (Mech.)	CHECKED BY <i>Bilal Khushid</i> J.E (Mech.)	APPROVED BY <i>Hamid Ali Raza</i> Plant Manager Dakhni	DRAWING NO. PP-DKN-629	
Scale: NTS	Computer Code PN.01	Rev. 0	Date 18-07-2019	