



OIL & GAS DEVELOPMENT COMPANY LIMITED
UCH GAS FIELD/PLANT, DERA BUGTI, BALOCHISTAN

Annexure-A

Schedule of Requirement

Tender Enquiry No: PROC-UGF (UCH-II)/MECH-002/2022,

"PROCUREMENT OF AIR INTAKE FILTERS FOR GAS TURBINES OF UCH-II PLANT"

Sr #	Description	Order Qty.	Unit Price (PKR)
1	AIR INTAKE FILTERS, CYLINDRICAL Size: 560mm L x 405mm OD x 293mm ID Make: AAF PART # 05AX-1 OR EQUIVALENT AS PER ATTACHED OEM SPECIFICATION SHEET ASY: GAS TURBINE "SIEMENS" MODEL 'SGT-100-1S'	72 Nos.	
2	AIR INTAKE FILTERS, CYLINDRICAL Size: 880mm L x 405mm OD x 293mm ID Make: AAF PART # 05AX OR EQUIVALENT AS PER ATTACHED OEM SPECIFICATION SHEET ASY: GAS TURBINE "SIEMENS" MODEL 'SGT-100-1S'	72 Nos.	

Terms & Conditions (Technical).

1. Product Specification is attached for technical/dimensional detail. If the bidder finds any ambiguity in specification, dimension or any technical detail / data, it should be clarified prior to bid submission.
2. Bidder must have minimum 05 years of experience in manufacturing/supply/OEM authorized distribution of similar filter elements and must provide the evidence that offered filters are being used in the different organizations along with technical bid.
3. In order to assure the quality & efficiency of the equivalent filter elements, Bidder shall provide evidence that such filters are being used in similar applications.
4. Bidder to confirm that filtration media will be European/USA/UK Origin and that 3rd party MTCs/ MSDS of Filter Media by corresponding OEM will be provided along with technical bid.
5. To avoid any dimensional discrepancy, bidder to confirm that after placement of Purchase Order, one filter of each size will be supplied as a sample at Uch Gas Field, OGDCL to check fitment with filter housing.

6. If required the filter element, sample can be provided to the successful bidder to avoid any ambiguity at later stage.
7. Bidder to confirm that each filter will be packed in secured and seaworthy robust packing. Handling instructions along with symbols also to be pasted on each packing.
8. Filters will be delivered at Uch Gas Field-OGDCL in secured packing.
9. Inspection of material will be carried out by the OGDCL rep. at Uch Gas Field.
10. Bidder to confirm that proposed filter elements would be 100% replacement of specified filters with same efficiency, fits & tolerances. Bidder has to provide the literature and relevant documents regarding equivalent Filter elements. Bidder must provide the detailed drawing(s), technical specification(s) and documentary evidence / proof that supplied Filter elements are exact replacement of Filter elements specified in this documents and other referred.
11. Delivery of material is to be completed in 60 days from the date of receipt of firm purchase order.

GENERAL TERMS AND CONDITIONS:

- A. BIDS MUST BE SUBMITTED UNDER **TWO ENVELOPES BIDDING SYSTEM** i.e. TECHNICAL & FINANCIAL BID SEPARATELY ON DUE DATE.
- B. FINANCIAL BIDS OF ONLY TECHNICALLY RESPONSIVE BIDDERS WILL BE OPENED PUBLICLY.
- C. AFTER TENDER OPENING "TECHNICAL BIDS" WILL BE REVIEWED. THE BIDS WILL BE BROUGHT TECHNICALLY AT PAR BY SEEKING CLARIFICATIONS. THE BIDDERS WILL **NOT** BE ASKED FOR ANY PRICE CHANGE IN THEIR FINANCIAL BIDS DUE TO CERTAIN CLARIFICATIONS AND SUBSEQUENT CHANGE IN THEIR TECHNICAL PROPOSALS. THE BIDDERS WILL **NOT** BE ALLOWED TO SUBMIT SUPPLEMENTARY PRICE PROPOSALS IN A SEPARATE SEALED ENVELOPE TO MAKE IT A PART OF THE ALREADY SUBMITTED UNOPENED FINANCIAL BIDS AND TO ADJUST THEIR QUOTED PRICE SUBSEQUENTLY AFFECTED DUE TO CHANGE IN TECHNICAL PROPOSALS.
- D. SEALED FINANCIAL BIDS OF TECHNICALLY NON-RESPONSIVE BIDDERS WILL BE RETURNED UN-OPENED.
- E. OGDCL RESERVES THE RIGHT TO REJECT ANY OR ALL THE BIDS WITHOUT ASSIGNING ANY REASON.
- F. PRICES MUST BE QUOTED IN PKR INCLUSIVE OF ALL TAXES AND DUTIES, INDICATING UNIT PRICE AND TOTAL BID PRICES. GST MUST BE QUOTED SEPARATELY ALONG WITH COPY OF GST CERTIFICATE.
- G. QUOTED PRICES SHALL BE VALID FOR **60 DAYS** FROM THE OPENING DATE OF THE TECHNICAL BID.
- H. OGDCL RESERVES THE RIGHT TO EVALUATE THE BID(S) EITHER ITEM-WISE OR FULL PASKAGE BASIS WITHOUT ASSIGNING ANY REASON. TO QUOTE COMPETITIVE PRICES FOR ALL OR ANY ITEMS ENABLE COMPANY TO DECIDE PURCHASE.
- I. THE MAXIMUM DELIVERY TIME FOR SUPPLY ITEMS IS **60 DAYS** FROM THE DATE OF RECEIPT OF FIRM PURCHASE ORDER.
- J. BIDDERS TO SUBMIT THEIR COMPANY PROFILES, EXPERIENCE OF SIMILAR SUPPLIES IN PAKISTAN ALONG WITH TECHNICAL BIDS.
- K. THE MASTER SET OF TENDER DOCUMENTS (LOCAL) AVAILABLE ON OGDCL WEBSITE (www.ogdcl.com) IS THE INTEGRAL PART OF THIS TENDER.



OIL & GAS DEVELOPMENT COMPANY LIMITED
UCH GAS FIELD/PLANT, DERA BUGTI, BALOCHISTAN
SCHEDULE OF REQUIREMENT

Mandatory Checklist

Please confirm the compliance of the following mandatory information along with the bid(s) failing which bid(s) will not be accepted.

Documents	To be attached with the Technical / Financial Bids	Compliance	
		Yes <input type="checkbox"/>	No <input type="checkbox"/>
Original Bid Bond	Technical Bid	Yes <input type="checkbox"/>	No <input type="checkbox"/>
Copy of NTN Certificate	Technical Bid	Yes <input type="checkbox"/>	No <input type="checkbox"/>
Copy of GST Certificate	Technical Bid	Yes <input type="checkbox"/>	No <input type="checkbox"/>
Confirmation that the Firm is appearing FBR's Active Taxpayer List	Technical Bid	Yes <input type="checkbox"/>	No <input type="checkbox"/>
Duly Signed and Stamped Annexure-A(Un-priced)	Technical Bid	Yes <input type="checkbox"/>	No <input type="checkbox"/>
Duly filled, signed and stamped Annexure-B	Technical Bid	Yes <input type="checkbox"/>	No <input type="checkbox"/>
Duly filled, signed and stamped Annexure-D	Technical Bid	Yes <input type="checkbox"/>	No <input type="checkbox"/>
Duly signed and stamped Annexure-L on Company's Letter Head	Technical Bid	Yes <input type="checkbox"/>	No <input type="checkbox"/>
Duly signed and stamped Annexure-M on Company's Letter Head	Technical Bid	Yes <input type="checkbox"/>	No <input type="checkbox"/>
Duly signed and stamped Annexure-N on Non-Judicial Stamp paper duly attested by Notary Public	Technical Bid	Yes <input type="checkbox"/>	No <input type="checkbox"/>
Duly Filled, signed and stamped Annexure-A (Priced)	Financial Bid	Yes <input type="checkbox"/>	No <input type="checkbox"/>
Duly Filled, signed and stamped Annexure-C	Financial Bid	Yes <input type="checkbox"/>	No <input type="checkbox"/>
Duly Filled, signed and stamped Annexure-E	Financial Bid	Yes <input type="checkbox"/>	No <input type="checkbox"/>

The above Annexures are available in MASTER SET OF TENDER DOCUMENTS (LOCAL) and can be downloaded from OGDCL website (www.ogdcl.com).

Product Specification

DuraKlean Canister Pair

**Part Number: 05AX (Cylinder)
05AX-1 (Cylindrical)**

Physical Specification

Dimensions:	Height: 875 mm (05AX) / 560 mm (05AX-1) Outer Diameter: 405 mm (each) Inner Diameter: 293 mm (each)
Filter Weight:	approximately 14.33kg
Bottom End Cap:	Electro-galvanised Steel – Open (05AX-1) Electro-galvanized steel–Closed type with 12.0 mm bolt hole (05AX)
Top End Cap:	Galvanised Steel – Open
Outer & Inner Liners:	Galvanised, expanded and flattened steel
Gasket:	Seamless polyisoprene gaskets eliminate bypass with 100% seal
Media Description:	AAF's DuraKlean Proprietary Blend Media
Pleat Spacing:	Pleat lock ensuring uniform pleat spacing on both inside and outside diameter for maximum life with minimal airflow restriction
End Cap Bonding:	End caps potted with chemical cured polyurethane eliminating air bypass and enhancing structural strength
Accessories:	Rubber step washer with metal insert as a standard option

Product Specification

DuraKlean Canister Pair

Part Number: 05AX (Cylinder)
05AX-1 (Cylindrical)

Performance Specification

Rated Airflow: 1650 cfm (2803 m³/hr)

Initial Pressure Drop: 206.5 Pa (0.83" w.g.)

Initial Efficiency @0.4micron: 17.1%

Average Efficiency: 90%

Dust Holding Capacity (ASHRAE):
1288g @ 450Pa
2299g @ 625Pa
3969g @ 1000Pa

Efficiency (EN779:2002): F8

Efficiency (ASHRAE 52.2): MERV 14

Burst Pressure: > 25" w.g



GAS TURBINE
DIVISION

BETTER AIR IS OUR BUSINESS®

Product Specification

DuraKlean Canister Pair

Part Number: 05AX (Cylinder)
05AX-1 (Cylindrical)

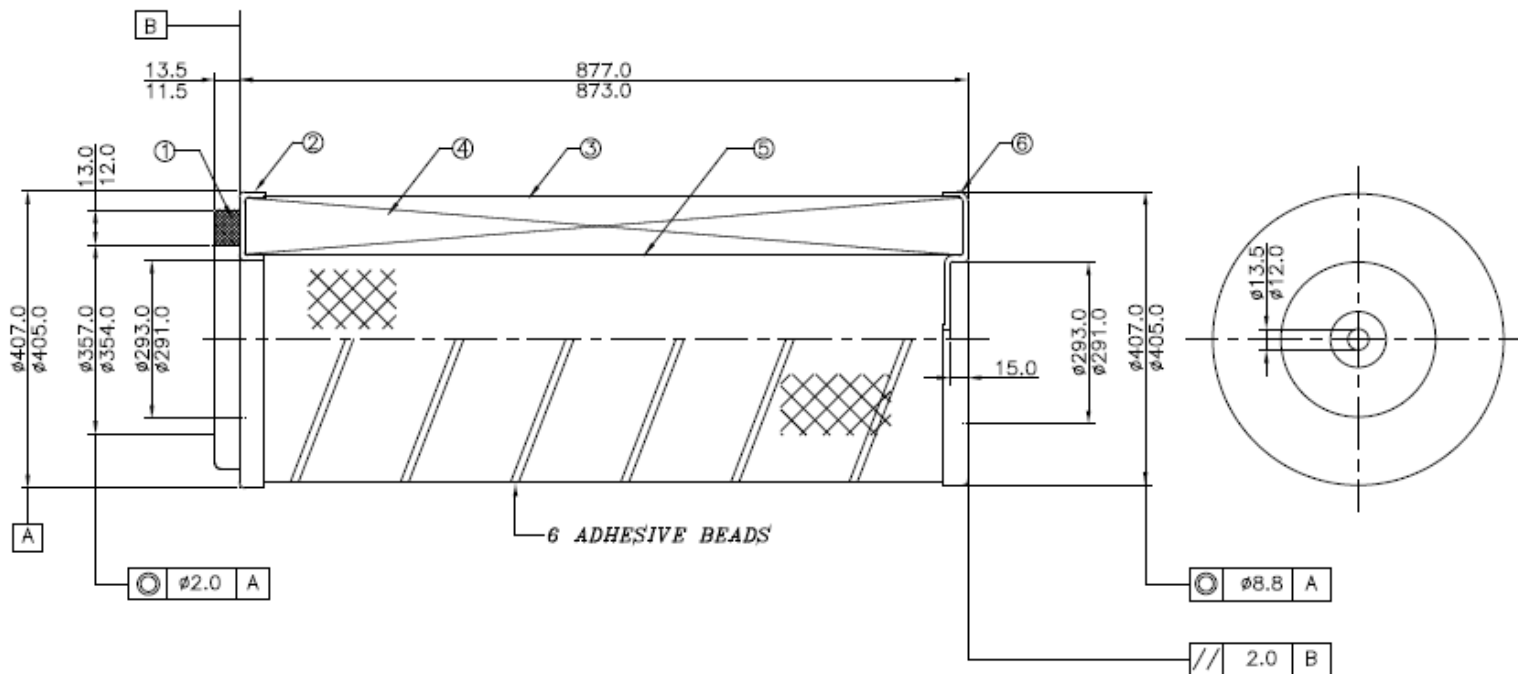



GAS TURBINE
DIVISION

BETTER AIR IS OUR BUSINESS®

Product Specification

DuraKlean Canister Pair

Part Number: 05AX-1 (Cylindrical)

