



**OIL & GAS DEVELOPMENT COMPANY LIMITED**  
**UCH GAS FIELD, DERA BUGTI-BALUCHISTAN**

Annexure-A

**Schedule of Requirement**

Tender Enquiry No. TE/UCH-I/ATA2021/M&I-001/2021

**“SUPPLY OF SPIRAL WOUND AND HEAT EXCHANGER GASKETS”**

<b>Group-A: SPIRAL WOUND GASKET (Make: KLINGER, FLEXITALLIC, THERMOSEAL, JEIL):-</b>			
<b>Sr. No.</b>	<b>Item Description</b>	<b>UOM</b>	<b>Qty.</b>
1	Size: 3/4 inch, CL 150 with outer ring	No.	42
2	Size: 3/4 inch, CL 600 with outer ring	No.	12
3	Size: 1 inch, CL 150 with outer ring	No.	70
4	Size: 1 1/2 inch, CL 150 with outer ring	No.	30
5	Size: 1 1/2 inch, CL 300/600 with outer ring	No.	32
6	Size: 2 inch, CL 150 with outer & inner ring	No.	78
7	Size: 2-1/2 inch, CL 150, with outer ring	No.	08
8	Size: 2-1/2 inch, CL 600 with outer & inner ring	No.	10
9	Size: 3 inch, CL 150 with outer & inner ring	No.	42
10	Size: 3 inch, CL 300 with outer & inner ring	No.	16
11	Size: 3 inch, CL 600 with outer & inner ring	No.	38
12	Size: 4 inch, CL 150 with outer & inner ring	No.	76
13	Size: 4 inch, CL 300 with outer & inner ring	No.	24
14	Size: 6 inch, CL 150 with outer ring	No.	124
15	Size: 6 inch, CL 600 with outer & inner ring	No.	48
16	Size: 8 inch, CL 150 with outer ring	No.	47
17	Size: 10 inch, CL 150 with outer ring	No.	68
18	Size: 10 inch, CL 300 with outer ring	No.	02
19	Size: 10 inch, CL 900 with outer & inner ring	No.	25
20	Size: 12 inch, CL 150 with outer ring	No.	83

21	Size: 16 inch, CL 150 with outer ring	No.	14
22	Size: 16 inch, CL 600 with outer & inner ring	No.	10
23	Size: 18 inch, CL 150 with outer ring	No.	12
24	Size: 20 inch, CL 150 with outer ring	No.	30
25	Size: 20 inch, CL 600 with outer & inner ring	No.	10
26	Size: 24 inch, CL 150 with outer ring	No.	25
27	Size: 24 inch, CL 600 with outer & inner ring	No.	10
<b>Group-B: HEAT EXCHANGER GASKET: (Make: Klinger, Thermoseal, )</b>			
Sr. No.	Item Description	UOM	Qty.
1	<b>Front Channel Gasket:</b> Material: Soft Steel double jacketed with flexible graphite filler, Size: 46.00"O.D.x 44.9375"ID.x 0.125"thk x0.6875" center rib width <b><u>(For Amine Reflux Condenser as per dwg# 658314)</u></b>	No.	4
2	<b>Rear Channel Gasket:</b> Material: Soft Steel double jacketd with flexible graphite filler, Size: 46.25" O.D.x 45.1875"ID.x0.125"thk <b><u>(For Amine Reflux Condenser as per dwg# 658314)</u></b>	No.	01
3	<b>Front /Rear Channel Gasket:</b> Material: Soft Steel double jacketd with flexible graphite filler, Size: 49.8125" O.D x 48.75"ID.x0.125"thk <b><u>(For Amine Solution Cooler as per dwg# 658315)</u></b>	No.	02
4	<b>Front/Rear Channel Gasket:</b> Material: Soft Steel double jacketed with flexible graphite filler, Size: 65.70"O.D.x 64.72"ID.x 0.125"thk <b><u>(For Amine Reboiler as per dwg# 658313-Rev01)</u></b>	No.	04
5	<b>Tube Side Gasket:</b> Material: Soft Steel double jacketed with flexible graphite fillerr Size: 685.8 mm O.D x 628.25 mm I.D x 5mm Thk with ribs <b><u>(for Glycol Reboiler as per attached dwg)</u></b>	No.	2
6	<b>Tube Side Gasket:</b> Material: Soft Steel double jacketed with flexible graphite filler Size: 263.7 mm O.D x 233.2 mm I.D x 5 mm Thk with ribs <b><u>(for Glycol Reboiler (Small Bundle) as per attached dwg)</u></b>	No.	2

**TERMS AND CONDITIONS (TECHNICAL):-**

1. Bidder/Supplier should quote gasket of brands mentioned with UK/European/Korean/ USA origin only.
2. Supplier shall submit Material Specification and Country of origin confirmation from OEM along with technical bid.
3. Material will be delivered at Uch Gas Field-OGDCL in original OEM packing.
4. Inspection of material will be carried out by the OGDCL rep. at Uch Gas Field
5. In case supplier fail to comply any of the above requirement the consignment may be deemed as rejected.
6. Delivery of material is to be completed in 45 days from the date of receipt of firm purchase order.
7. Bids evaluation criteria will be group wise.
8. The master set of tender documents (Local) available on OGDCL website ([www.ogdcl.com](http://www.ogdcl.com)) is the integral part of this tender.

**GENERAL TERMS AND CONDITIONS:**

- A. BIDS MUST BE SUBMITTED UNDER **TWO ENVELOPES BIDDING SYSTEM** i.e. TECHNICAL & FINANCIAL BID SEPARATELY ON DUE DATE.
- B. FINANCIAL BIDS OF ONLY TECHNICALLY RESPONSIVE BIDDERS WILL BE OPENED PUBLICLY.
- C. AFTER TENDER OPENING "TECHNICAL BIDS" WILL BE REVIEWED. THE BIDS WILL BE BROUGHT TECHNICALLY AT PAR BY SEEKING CLARIFICATIONS. THE BIDDERS WILL **NOT** BE ASKED FOR ANY PRICE CHANGE IN THEIR FINANCIAL BIDS DUE TO CERTAIN CLARIFICATIONS AND SUBSEQUENT CHANGE IN THEIR TECHNICAL PROPOSALS. THE BIDDERS WILL **NOT** BE ALLOWED TO SUBMIT SUPPLEMENTARY PRICE PROPOSALS IN A SEPARATE SEALED ENVELOPE TO MAKE IT A PART OF THE ALREADY SUBMITTED UNOPENED FINANCIAL BIDS AND TO ADJUST THEIR QUOTED PRICE SUBSEQUENTLY AFFECTED DUE TO CHANGE IN TECHNICAL PROPOSALS.
- D. SEALED FINANCIAL BIDS OF TECHNICALLY NON-RESPONSIVE BIDDERS WILL BE RETURNED UN-OPENED.
- E. OGDCL RESERVES THE RIGHT TO REJECT ANY OR ALL THE BIDS WITHOUT ASSIGNING ANY REASON.
- F. PRICES MUST BE QUOTED IN PKR INCLUSIVE OF ALL TAXES AND DUTIES, INDICATING UNIT PRICE AND TOTAL BID PRICES. GST MUST BE QUOTED SEPARATELY ALONG WITH COPY OF GST CERTIFICATE.
- G. QUOTED PRICES SHALL BE VALID FOR **90 DAYS** FROM THE OPENING DATE OF THE TECHNICAL BID.
- H. OGDCL RESERVES THE RIGHT TO EVALUATE THE BID(S) EITHER ITEM-WISE OR FULL PASKAGE BASIS WITHOUT ASSIGNING ANY REASON. TO QOUTE COMPETITIVE PRICES FOR ALL OR ANY ITEMS ENABLE COMPANY TO DECIDE PURCHASE.
- I. THE MAXIMUM DELIVERY TIME FOR SUPPLY ITEMS IS **45 DAYS** FROM THE DATE OF RECEIPT OF FIRM PURCHASE ORDER.
- J. BIDDERS TO SUBMIT THEIR COMPANY PROFILES, EXPERIENCE OF SIMILAR SUPPLIES IN PAKISTAN ALONG WITH TECHNICAL BIDS.



**OIL & GAS DEVELOPMENT COMPANY LIMITED**  
**PROCUREMENT DEPARTMENT (LOCAL), ISLAMABAD**  
**SCHEDULE OF REQUIREMENT**

**Mandatory Checklist**

Please confirm the compliance of the following mandatory information along with the bid(s) failing which bid(s) will not be accepted.

Documents	To be attached with the Technical / Financial Bids	Compliance	
		Yes <input type="checkbox"/>	No <input type="checkbox"/>
Original Bid Bond	Technical Bid	Yes <input type="checkbox"/>	No <input type="checkbox"/>
Copy of NTN Certificate	Technical Bid	Yes <input type="checkbox"/>	No <input type="checkbox"/>
Copy of GST Certificate	Technical Bid	Yes <input type="checkbox"/>	No <input type="checkbox"/>
Confirmation that the Firm is appearing FBR's Active Taxpayer List	Technical Bid	Yes <input type="checkbox"/>	No <input type="checkbox"/>
Duly Signed and Stamped Annexure-A(Un-priced)	Technical Bid	Yes <input type="checkbox"/>	No <input type="checkbox"/>
Duly filled, signed and stamped Annexure-B	Technical Bid	Yes <input type="checkbox"/>	No <input type="checkbox"/>
Duly filled, signed and stamped Annexure-D	Technical Bid	Yes <input type="checkbox"/>	No <input type="checkbox"/>
Duly signed and stamped Annexure-L on Company's Letter Head	Technical Bid	Yes <input type="checkbox"/>	No <input type="checkbox"/>
Duly signed and stamped Annexure-M on Company's Letter Head	Technical Bid	Yes <input type="checkbox"/>	No <input type="checkbox"/>
Duly signed and stamped Annexure-N on Non-Judicial Stamp paper duly attested by Notary Public	Technical Bid	Yes <input type="checkbox"/>	No <input type="checkbox"/>
Duly Filled, signed and stamped Annexure-A (Priced)	Financial Bid	Yes <input type="checkbox"/>	No <input type="checkbox"/>
Duly Filled, signed and stamped Annexure-C	Financial Bid	Yes <input type="checkbox"/>	No <input type="checkbox"/>
Duly Filled, signed and stamped Annexure-E	Financial Bid	Yes <input type="checkbox"/>	No <input type="checkbox"/>

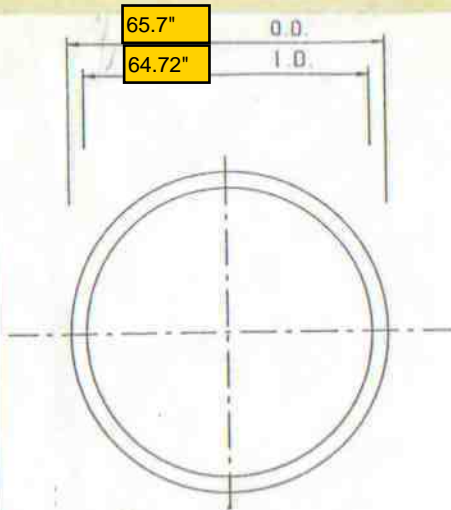

④ ONE (1) - REQUIRED  
 FRONT CHANNEL COVER GASKET  
 1/8" THK. STL. DOUBLE JACKETED  
 W/ FLEXIBLE GRAPHITE FILLER.

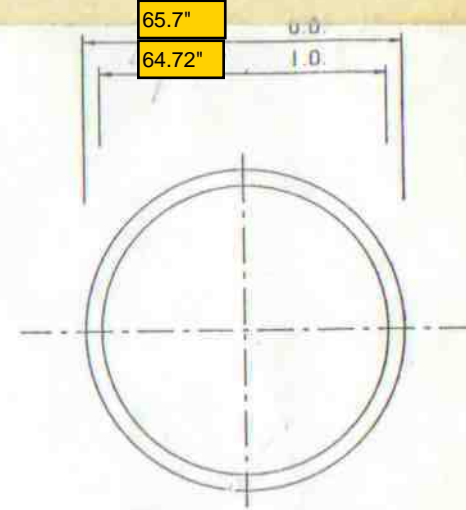

④ ONE (1) - REQUIRED  
 REAR CHANNEL COVER GASKET  
 1/8" THK. STL. DOUBLE JACKETED  
 W/ FLEXIBLE GRAPHITE FILLER.

NOTES:

- 1) QUANTITIES SHOWN FOR ONE (1) SET  
 THREE (3) SETS REQUIRED TOTAL.
- ONE (1) SET OF GASKETS TO BE USED IN EXCH. AND  
 TWO (2) SETS TO BE BOXED, MARKED WITH  
 P.O. & ITEM NO. & SHIPPED WITH EXCHANGER.
- 2) ALL JACKETED GASKETS TO HAVE  
 LAP OF GASKET NEAR SIDE.

					CUSTOMER: PETROSIN			
					OHMSTEDE JOB NO.: 658313			
					P.O. NO.: P181/8002			
					ITEM NO.: 18-E-201/20-E-201 <b>121 UNITS REQ'D.</b>			
					SERVICE: AMINE STRIPPER REBOILER			
1	RELEASE FOR FABRICATION	MS	DC	3-7-97	<b>GASKET DETAILS</b>			
2	FOR CUSTOMER APPROVAL	JSS	DC	1-7-97				
NO	REVISIONS	BY	CHK.	DATE CHK.	<b>OHMSTEDE</b>	DRAWING NO. 658313	SHEET NO. 12	REV. 1

3

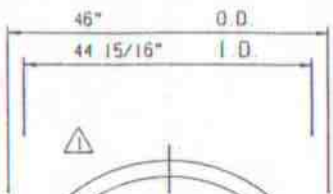

40 ONE (1) - REQUIRED  
FRONT CHANNEL COVER GASKET  
1/8" THK. STL. DOUBLE JACKETED  
W/ FLEXIBLE GRAPHITE FILLER,  
LAMONS STYLE 300-XL.

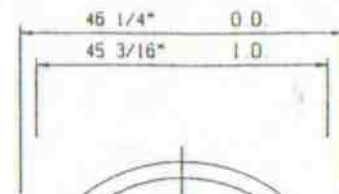

40 ONE (1) - REQUIRED  
REAR CHANNEL COVER GASKET  
1/8" THK. STL. DOUBLE JACKETED  
W/ FLEXIBLE GRAPHITE FILLER.

NOTES:

- 1) QUANTITIES SHOWN FOR ONE (1) SET  
THREE (3) SETS REQUIRED TOTAL.  
ONE (1) SET OF GASKETS TO BE USED IN EXCH. AND  
TWO (2) SET TO BE BOXED, MARKED WITH  
P.O. & ITEM NO. & SHIPPED WITH EXCHANGER.
- 2) ALL RADII TO BE 1/4"
- 3) ALL JACKETED GASKETS TO HAVE  
LAP OF GASKET NEAR SIDE.

					CUSTOMER: PETROSIN
					OHMSTEDE JOB NO.: 658314
					P.O. NO.: P181/0002
					ITEM NO.: 18-E-202/20-E-202 <b>121 UNITS REQ'D.</b>
					SERVICE: AMINE STRIPPER REFLUX CONDENSER
1	RELEASE FOR FABRICATION	HS	DC	3-7-97	<b>GASKET DETAILS</b>
0	FOR CUSTOMER APPROVAL	LJSS	DC	1-9-97	
NO.	REVISIONS	BY	CHK	DATE CHK	OHMSTEDE
					DRAWING NO. 658314
					SHEET NO. 12
					REV. 1

4

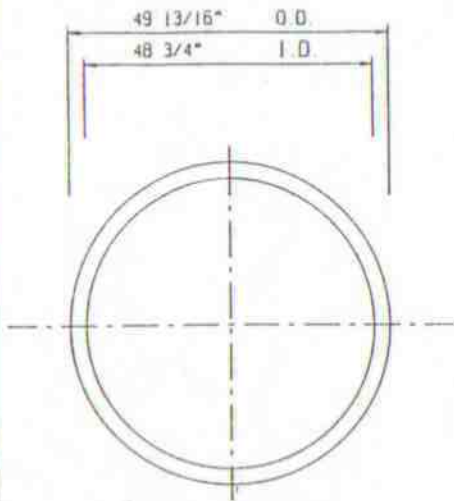

⚠ (48) ONE (11) - REQUIRED  
FRONT CHANNEL COVER GASKET  
1/8" THK. SOFT STL. DOUBLE JACKETED  
W/ FLEXIBLE GRAPHITE FILLER.

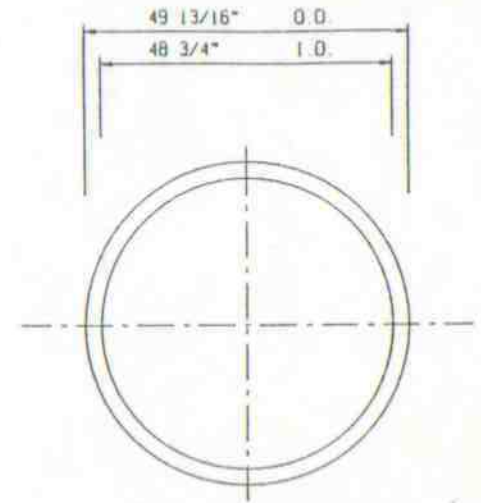

⚠ (48) ONE (11) - REQUIRED  
REAR CHANNEL COVER GASKET  
1/8" THK. SOFT STL. DOUBLE JACKETED  
W/ FLEXIBLE GRAPHITE FILLER.

- ⚠ NOTES:
- 1) QUANTITIES SHOWN FOR ONE (11) SET  
THREE (3) SETS REQUIRED TOTAL.  
ONE (11) SET OF GASKETS TO BE USED IN EXCH. AND  
TWO (2) SETS TO BE BOXED, MARKED WITH  
P.O. & ITEM NO. & SHIPPED WITH EXCHANGER
  - 2) ALL JACKETED GASKETS TO HAVE  
LAP OF GASKET NEAR SIDE.

					CUSTOMER: PETROSIN			
					OHMSTEDE JOB NO.: 658315			
					P.O. NO.: P181/0802			
					ITEM NO.: 18-E-283/28-E-283 <b>121 UNITS REQ'D.</b>			
					SERVICE: AMINE SOLUTION COOLER			
1	RELEASE FOR FABRICATION	MS	DC	3-18-97	<b>GASKET DETAILS</b>			
8	FOR CUSTOMER APPROVAL	JUSS	DC	1-14-97				
NO.	REVISIONS	BY	CHK.	DATE CHK	OHMSTEDE	DRAWING NO. 658315	SHEET NO. 12	REV. 1

35



# GLYCOL RE-BOILER (MAIN BUNDLE) GASKET

ITEM 15 : DETAIL OF GASKET (N° 8 PASSES)

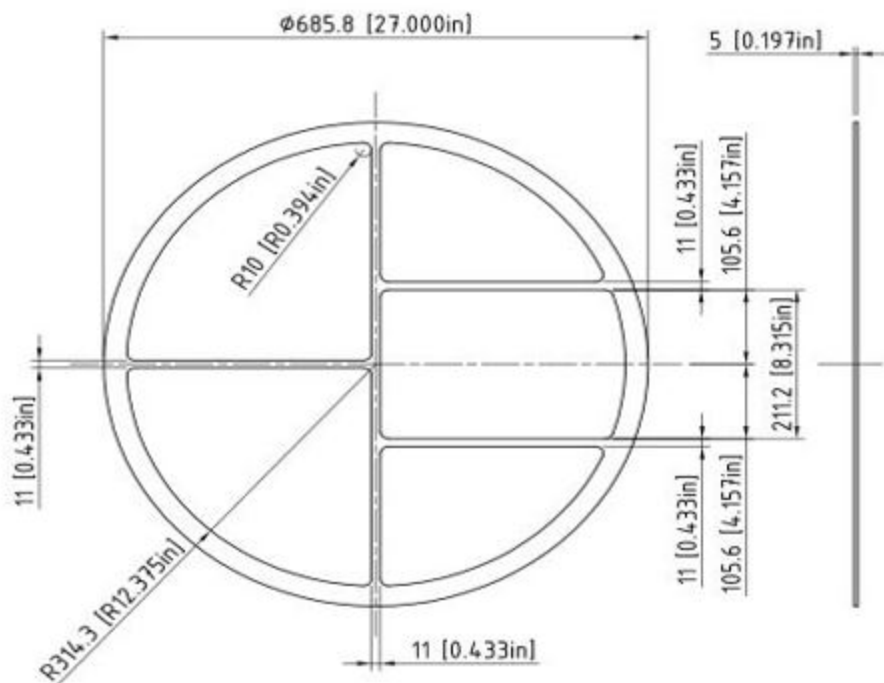

15	1	GASKET	SEE DETAIL	GRAPHITE	-	-	-	-
13	1	GASKET	[24-150-316L-F.G	316L SS	-	-	[B16.20]	-

# GLYCOL RE-BOILER (SMALL BUNDLE) GASKET

ITEM 20 : DETAIL OF GASKET (N° 4 PASSES)

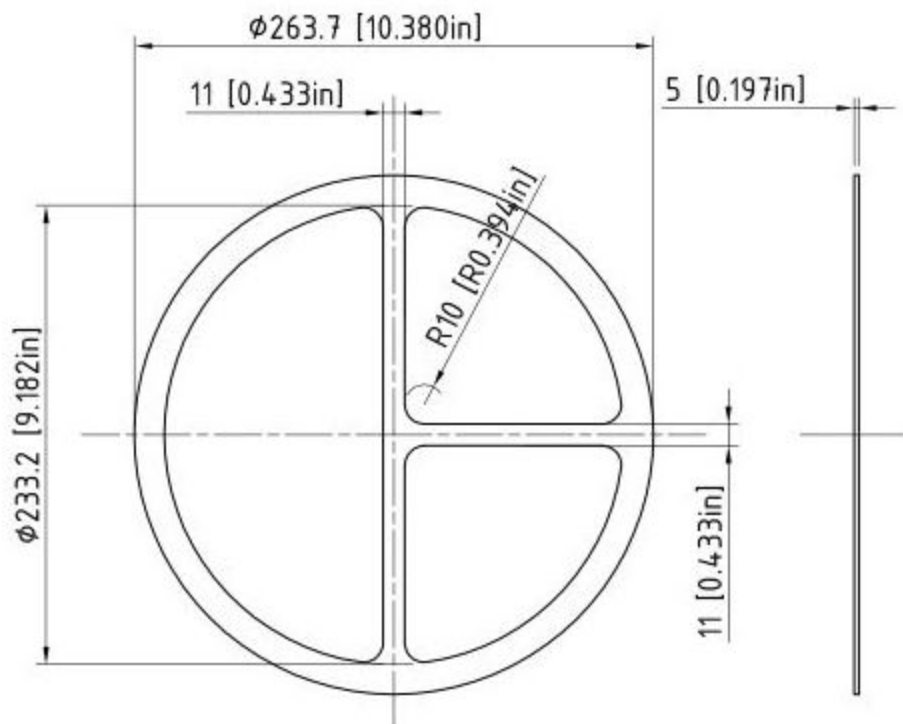

20	1	GASKET	SEE DETAIL	GRAFHITE	-	-	-	-
19	1	GASKET	8-150-316L-F.G.	316L SS	-	-	B16.20	-